



Brief profile
Product development
Quality management

Company profile



1

Equipment possibilities
at a glance

E-Mobility icons

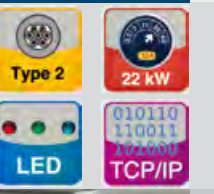

2

Application examples
Charging infrastructure

E-Mobility scenarios



3

Ecolectra product line
Voltanea product line
Amperea product line
Operation and communication

Product range
charging stations /
E-Station



4

Industry-Line product line
Design-Line product line
Robust-Line product line
Slim-Line product line
Special solutions (trolley, suspension-type combination, portable solid rubber distributor)

Product range
Wallbox / E-BoxX



5

Product range
charging possibilities
for e-Bikes



6

Marketing /
added-value services
for charging infrastructure
products



7

Overview of electric cars
and necessary charging cable
Mode 2 and mode 3 charging cables
Charging sockets and vehicle inlets
Charging plugs and vehicle connectors
Accessories: EV-tester, charge controller

Product range
charging cables,
charging connections
and accessories



8

Basic knowledge
in the area of electric
mobility



9

Training opportunities
for installers, wholesalers
and customers



10

Contacts at Walther



11

Foldout page
E-Mobility icons



- Plugs and Sockets
- Industrial Connectors
- E-Mobility
- Power Distributors for Outside Areas

E-Mobility 2013

Operator scenarios

Products and icons





Walther's headquarters, Eisenberg

Bosecker subsidiary, Zittau

Brief profile

Walther-Werke was founded back in 1897 in Grimma, near to Leipzig. Today, the owner-operated company has its headquarters in Eisenberg (Rhineland Palatinate), between Mannheim and Kaiserslautern, and is thus located centrally in Germany and Europe. More than 350 people work in the entire Walther Group worldwide, and are involved in development, production and sales of industrial connectors, CEE plugs and sockets, power distributors and transformer stations. For more than 75 years now, the subsidiary, Bosecker Verteilerbau, has been successfully producing power distributors and transformer stations. In addition, there are sales partnerships in more than 60 countries. In this way, we can guarantee optimum service for our customers on the spot at all times.

Core business of Walther for 115 years...



... leads to comprehensive E-Mobility expertise



Walther has held leading positions on all relevant standardisation committees since day one:



Product development

Our developers have extensive expertise in all relevant product and production requirements. In this way, we are able to work out solutions which will withstand the future challenges of electric mobility in the long term. Our significant production depth and broad product range mean that we can deliver a system solution comprising ideally matching components.



Project management

Each project starts with an idea. The project managers at Walther-Werke always provide our customers with advice and support that is up-to-date and at the appropriate level. Constructive exchange, extensive skills and experience combined with communication and transparency are our guidelines for shared success in a project.



Quality management

We aim to offer the highest level of quality consistently. For us, quality starts with product development (FMEA, AQPQ, etc.) and extends throughout the entire lifecycle of the product. In order to meet our customers' exacting requirements in full, we are currently expanding our ISO 9001 certification to the automobile standard, ISO TS 16949.



Success for our customers and partners

The combination of many years of product experience and cutting-edge specialist knowledge of methodology makes us the ideal partner for putting your ideas into practice. In addition to cooperating with various national and international automobile manufacturers, power utilities and other pioneers in electric mobility, we are already working successfully in the German market on E-Mobility projects with our traditional partners: the electrical wholesale trade and electricians.



Walther E-Mobility icons: Equipment features at a glance

Charging point

Type 1	Type 2	Type 2	Type 2	Type 2	Type 2	Type 3	Schuko	CEE	
Vehicle connector type 1 (vehicle side) acc. to IEC62196-2 for 16 A or 32 A, for single-phase charging. The vehicle connector is fixed to the charging device or charging cable.	Charging plug type 2 (infrastructure side) acc. to IEC62196-2 for 16 A, 32 A or 63 A, for single-phase or three-phase charging. The charging plug is fixed to the charging cable.	Vehicle connector type 2 (vehicle side) acc. to IEC62196-2 for 16 A, 32 A or 63 A, for single-phase or three-phase charging. The vehicle connector is fixed to the charging device or charging cable.	Charging socket type 2 (infrastructure side) acc. to IEC62196-2 for 16 A, 32 A or 63 A, for single-phase or three-phase charging. As variants with/without lid and electromechanical interlock for installation in charging devices.	Charging socket type 3 (infrastructure side) acc. to IEC62196-2 for 16 A or 32 A, for single-phase or three-phase charging. With lid and electromechanical interlock for installation in charging devices.	Schuko socket (infrastructure side) for max. 16 A, for single-phase charging. With lid and proximity detector for installation in charging devices.	CEE socket (infrastructure side) for 16 A or 32 A, for single-phase or three-phase charging. With lid and proximity detector for installation in charging devices.			Spiral cable with corresponding conductor cross-section in charging cable or fixed connection to the charging device.

Charging power

3,7 kW	7 kW	11 kW	22 kW	44 kW
The charging device or charging cable is designed for a max. charging power of 3.7 kW according to a charging current of 16 A (single-phase).	The charging device or charging cable is designed for a max. charging power of 7 kW according to a charging current of 32 A (single-phase).	The charging device or charging cable is designed for a max. charging power of 11 kW according to a charging current of 16 A (three-phase).	The charging device or charging cable is designed for a max. charging power of 22 kW according to a charging current of 32 A (three-phase).	The charging device or charging cable is designed for a max. charging power of 44 kW according to a charging current of 63 A (three-phase).

Technology

DJB	RCD A	RCD B	external RCD	IP 44	ABS	Stainless Steel	Alu
A complete connection acc. to the special requirements of the energy supplier (DJB, meter enclosure, SLS switch, empty enclosure, etc.) is provided at the supply point of the charging device.	A type A RCD (residual current device) is provided for each charging point. Type A does not take account of any DC fault currents > 6 mA from the electric vehicle.	A type B RCD (residual current device) is provided for each charging point. Type B (AC/DC sensitive) takes account of DC fault currents > 6 mA from the electric vehicle.	A type B RCD (residual current device) is provided for each charging point. Type B (AC/DC sensitive) takes account of DC fault currents > 6 mA from the electric vehicle.	The product has the IP rating IP 44.	The enclosure of the charging device is configured as a plastic enclosure.	The enclosure of the charging device is configured as a stainless steel enclosure.	The enclosure of the charging device is configured as an aluminium enclosure.

6.9 kWh int. meter	6.9 kWh meter	6.9 kWh → data
Energy meters (single-phase or three-phase) are provided in the charging device for occasional reading, in order to measure the energy consumed.	Energy meters (single-phase or three-phase) are provided for direct reading, in order to measure the energy consumed.	Energy meters (single-phase or three-phase) are provided on each charging unit for measuring the energy consumed. The consumption values are available as data via an interface.

Identification and operation (see chap. 4)

Key	Knob	LED	Display	Touchscreen	LPIN	LTAN	eTAN
The identification and release of each charging point is performed using key-operated switches (which can be removed in the on and off positions, allocation to the charging point according to the labelling).	The identification and release of each charging point is performed using knob switches (on and off position, and allocation to the charging point according to the labelling).	Signalling and operating indicator of the charging device by means of light-emitting diodes (LEDs) in the operating area (charging green, malfunction red, etc.).	Operating indicator and communication between the operator and the charging device via multi-line display in the operating area.	Operating indicator and communication between the operator and the charging device via touchscreen monitor. Inputs via onscreen keypad or buttons. Display of publicity information (slideshow) as added-value service.	With a localPIN, the operator enters his/her personal PIN on the monitor. This is verified against the internal local list, and the charging point is released if the check proves positive.	In a localTAN, the operator is displayed a TAN with a mobile phone number on the monitor. The operator sends this localTAN as an SMS to the indicated mobile phone number, and the charging point is released.	In an extendedTAN, the operator is displayed a TAN on the monitor. The operator (registered customer, e.g. with mobile phone ticket) transfers this extendedTAN via SMS to the provider, and receives a TAN in return. After inputting this on the monitor, the charging point is released.

Data communication

Tokens	RFID	eRFID	Mobile phone	OCPP	TCP/IP
The charging energy is paid for using tokens. The operator defines the price per kWh (with consumption measurement) or a flat-rate price per unit of time (with time recording).	Identification is by means of an RFID medium. After verification against the internal local list, the charging point is released, and the consumption data is allocated to the RFID.	Identification is by means of an RFID medium. Following verification by the provider (e.g. charging network), the charging point is released and the consumption data allocated to the RFID.	Communication (authentication or data transfer) with the charging device takes place via mobile phone.	Communication between the charging device and backend takes place via the OCPP protocol (e.g. charging network as operator).	Communication with the charging device (permanent or periodic) takes place via TCP/IP.

Added-value services and CI livery (see chap. 7)

abc media	E-BoxX E-Station	Slideshow	RAL 9010	RAL 9005/9006	RAL Customer	RAL bicolor
The enclosure of the charging device can be used as a publicity surface or CI measure by means of foils.	Illuminated publicity surfaces are available as a top unit for the charging device.	Display of marketing messages (slideshow) as added-value service on the integrated touchscreen monitor.	The enclosure of the charging device is painted in RAL 9010 (pure white) as the standard colour.	The enclosure of the charging device is painted in RAL 9005 (jet black) and RAL 9006 (white aluminium).	At the customer's request, the enclosure of the charging device can be painted in one colour (selected from the RAL swatch).	At the customer's request, the enclosure of the charging device can be painted in two colours (selected from the RAL swatch).

Walther E-Mobility icons represent the extensive properties, possibilities and variants of the product and solutions at a glance, and are structured into the following groups: charging point, charging power, technology, identification and operation, data communication, added-value services and CI livery.

Private

Operator



Garage

Carport / street

- Robust solution for the outside area
- Solar carport with charging point
- Entry-level solution for charging in the private garage

Pages 8 - 13



Research & development

- Outside system for charging tests and data recording
- Mobile charging solution in the trolley case
- Varied solutions for charging in laboratory equipment

Pages 14 - 19



Fleet

- Complete system for charging large company fleets
- “Express“ charging system by colour coding
- Satellite system with data transfer for fleet management requirements
- Connection of charging stations to alternative sources of energy
- Representative charging systems, taking the example of a car dealership
- Charging the company’s own electric car and visitors’ vehicles
- Equipping a modern, comprehensive housing project with charging points

Pages 20 - 33



Marketing

- Charging station on customer’s car park as a marketing instrument with additional benefit
- Free charging possibility on customers’ car parks, taking the example of the electrical wholesale trade
- Charging possibility for electric bikes, taking the example of restaurants/hotels
- Employees’ car park with E-BoxX units on a post system

Pages 34 - 41



Business model

- Flexible, decentralised settlement solution for utilities (own fleet and customers)
- Central settlement solution via online IT system with secure protocol (OCPP)
- LocalTAN process via SMS communication with the charging station
- ExtendedTAN process via SMS communication with the provider
- Access-free charging system in multi-storey car parks
- Connection of charging stations to existing parking ticket vending machines
- Charging station reservation and charging timing for airports and railway stations
- Coin payment system with receipt delivery
- Car sharing with online availability requests (charging station and vehicle)

Pages 42 - 59



Electrical trade

/ Installer

• Test equipment for installation and maintenance activities (“e-check”)

Pages 60 - 61

Walther application scenarios:

A tool for turning your E-Mobility ideas into reality!

The Walther application scenarios described over the following pages are intended to assist you as the reader in turning your own ideas into reality based on the project outlines described. Over recent years at Walther, we have discussed hundreds of project ideas in the area of electric mobility with

our customers and project partners in Germany and abroad, many of which have been put into practice. In doing so, we gained valuable practical experience above all else. On the basis of this experience, we have now attempted to categorise the main user groups. We have then described some typical examples for each user group, in accordance with the requirements that we have become familiar with over recent years. In doing this, it is important to provide not only a general description of the scenario, but also to give an opinion regarding the underlying technical challenges of implementation – because

theoretical concepts of E-Mobility are one thing, whereas installing a functioning and stable system is quite a different kettle of fish. One of the main things we have noticed is that despite each customer project being basically similar, they do have highly individual characteristics. As a result, we have attempted in each scenario to offer sensible product variants as well as additional options in order to indicate further configuration options for you. In this way, we intend to give you the opportunity to select a scenario as the basis for discussion in a project meeting with our project managers, and then introduce individual adaptations on this basis. We hope that over

the following pages we will be able to provide you with ideas so that your E-Mobility project can soon become reality. We look forward to helping you with this!

Another tip: The best way of reading the scenarios is in conjunction with our E-Mobility icon list. To do this, simply fold out the last page of the catalogue when you are looking at the scenarios.

Private:
Robust solution for the outside area

Private:
Robust solution for the outside area

Situation:

Private individuals who want to purchase an electric vehicle are always immediately faced with the question of how and where their electric car should be charged. Not all users have their own garage, therefore it may be necessary to install a charging point on the outside of the house or in the garden. This public access means that protection against vandalism must be provided, and the enclosure must offer the corresponding level of stability. Furthermore, the installation location (private premises or public road; wall mounting or in the open) is important in planning the charging facility. This brings up issues such as possibilities for routing the electric feeder cable, energy metering and security, as well as the type of installation. On the one hand, it could be a wall installation, or on the other hand an E-BoxX could be installed in the open on a post or a charging station.

Solution:

Walther offers a sturdy and visually appealing solution made from high-quality stainless steel to meet this scenario with the Robust-Line E-BoxX series. Behind a lockable door, there is a knob switch that is used for starting the charging procedure. The Robust-Line also offers sufficient space for security elements such as the RCBO and optional meters. As an upgrade,

it is also possible to equip the Robust-Line with a fixed charging cable. This increases convenience in everyday charging. As a downgrade, the Industry-Line E-BoxX represents an alternative. This lower-cost solution can also be equipped with a key-operated switch.



upgrade ↑

→

↓ downgrade

Product from scenario



Robust-Line

- Type 2
- Schuko
- 3,7 kW
- 22 kW
- LED
- RCBO B
- IP 44
- RAL

98300107, see page 78



Robust-Line

- Type 2
- 11 kW
- LED
- RCBO B
- IP 44
- RAL

98300104, see page 79



Industry-Line

- Type 2
- 11 kW
- LED
- RCBO B
- IP 44
- RAL

98100112, see page 75

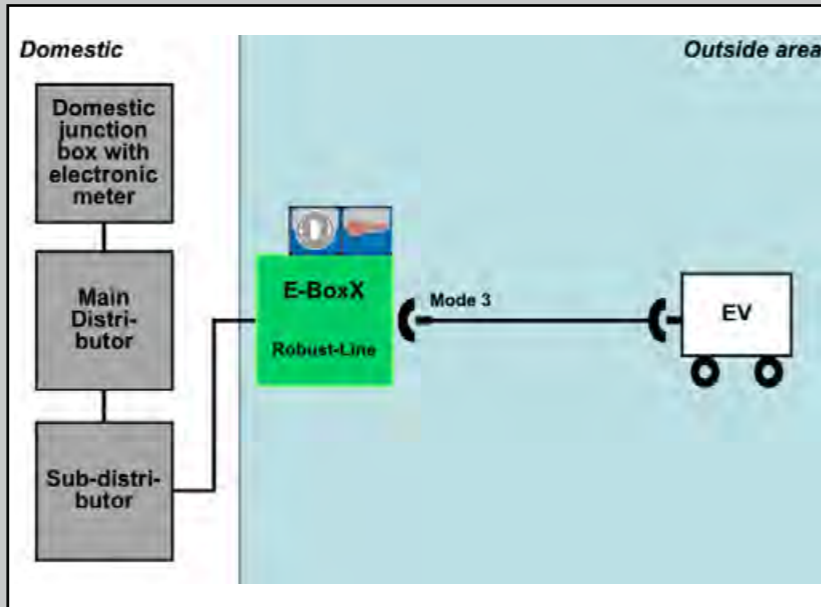

Description of function:

The driver inserts the charging plug into the corresponding charging socket. The door of the E-BoxX is opened using a key, thus providing access to the safety elements, meter and, above all, the knob switch that allows the charging procedure to be started and completed. When the charging procedure starts, the connector in the charging socket is mechanically locked. This ensures that no unauthorised persons disconnect the charging plug, or are able to use the charging point in general, without the owner's permission.

Interesting features:

Walther solutions always offer the option of equipping the charging device with a charging cable in a fixed connection, and the corresponding vehicle connector. This is possible both for type 1 and type 2 plugs and sockets. This charging cable can be locked behind a door in some variants of the Robust-Line series in order to prevent misuse.

In order to allow a better understanding of the functions described here, the fold-out page at the back of the catalogue provides corresponding explanations. Detailed product descriptions about charging stations, E-BoxX units, charging cables, etc. can be found in the corresponding chapters over the following pages.

Optional products and configuration possibilities

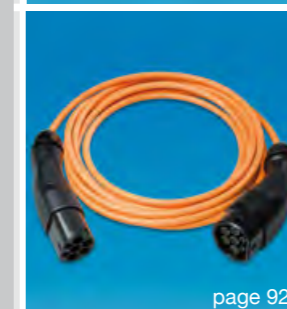
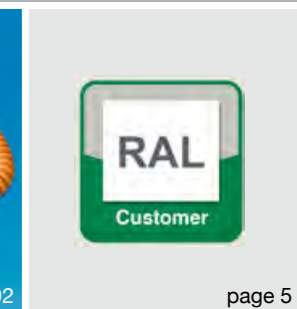
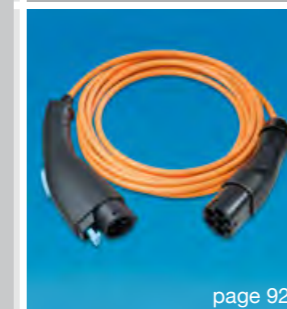

Private: Solar carport with charging point

Situation:

Basically, electric mobility only really makes sense if the charging current used is drawn from alternative sources of energy such as solar, wind or water. In the private sphere too, many users of electric vehicles want to set an example. One such example involves using an existing or newly installed solar installation as the source of energy, and connecting the charging facility here, depending on the type of energy use (feeding into the public grid, own use). This solar installation can be fitted both on the roof of a house or on a carport. Assuming a battery charge of 15 kWh, a solar installation with 3 kWp would require approx. 5 hours to completely charge the vehicle.



Solution:

The solar installation is connected to the mains in the usual way via an inverter. An E-BoxX of the Slim-Line product line is connected to the PV installation via a combined distributor. The E-BoxX can be equipped with a fixed cable, thus allowing the vehicle to be connected easily. As an alternative and as a downgrade, it is possible to use a Robust-Line E-BoxX. In this case, access can be restricted by

means of a lockable door, meaning that only authorised people are able to use the charging point. One possible upgrade would be a VOLTANEA product line charging station, which allows the inverters to be integrated here. In this case too, it is possible to restrict access by means of key-operated switches.

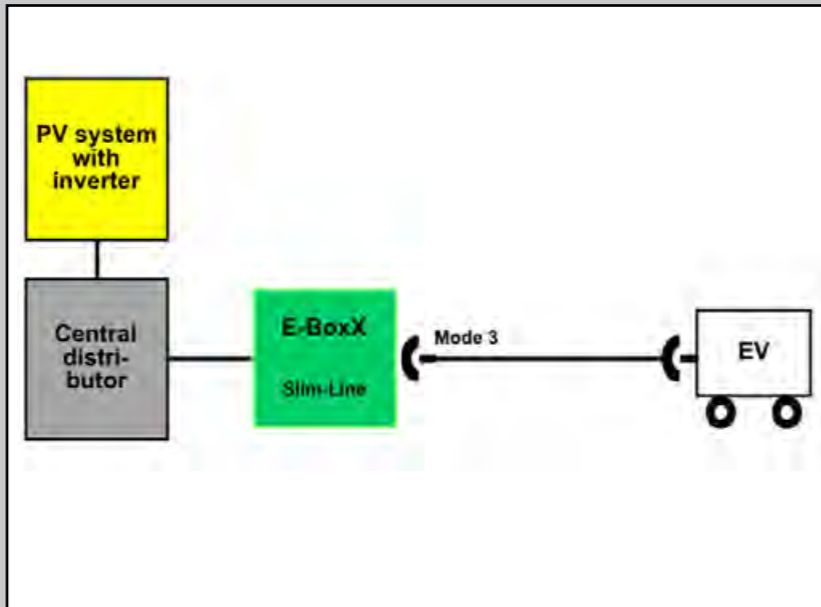

Description of function:

If the customer chooses an E-BoxX from the Slim-Line product line without access restriction, the procedure would be as follows: The customer connects his/her vehicle and the charging procedure starts immediately (type 1 plug) or after activating the knob switch (type 2 plugs and sockets). The charging process is terminated by disconnecting the plug (type 1 plug) or by switching off and then disconnecting the plug (type 2 plugs and sockets).

Interesting features:

Intelligent charging systems represent a sensible way of adapting the own-generated proportion of energy generated by PV installations. Simple control models allow for dynamic load management under optimum customer conditions. It is also a good idea to input the available charging time window here.

In future, external accumulator solutions will permit more independent electricity supply for charging electric vehicles.

In order to allow a better understanding of the functions described here, the fold-out page at the back of the catalogue provides corresponding explanations. Detailed product descriptions about charging stations, E-BoxX units, charging cables, etc. can be found in the corresponding chapters over the following pages.

Private:
Solar carport with charging point

Product from scenario

upgrade ↑



downgrade ↓

VOLTANEA

M 68K0 10E00 60
see page 66

Slim-Line

98200105, see page 81

Robust-Line

98300103, see page 78

Optional products and configuration possibilities

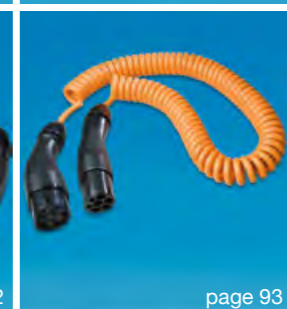
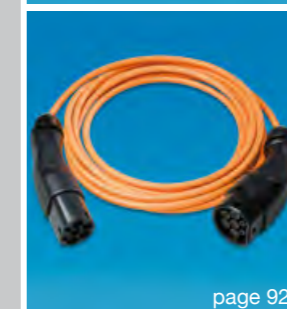
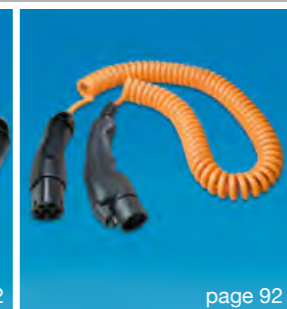
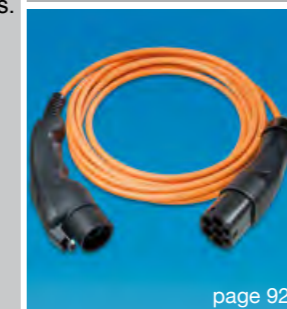

Private:
Entry-level solution for charging in a private garage

Private:
 Entry-level solution for charging in a private garage

Situation:

After having bought an electric vehicle, its owner would like to charge the vehicle in his/her garage. After having checked the electrical installation, the electrician will decide whether an existing supply cable is sufficient, or if a new one will have to be installed. This also concerns the necessary safety precautions which are provided in the existing distribution system. Furthermore, the user can freely decide whether to install an elegant design solution, or to concentrate on the cost aspect – with regard to the installation equipment that must be fitted in the E-BoxX on the basis of the electrician's analysis. Also, the space available in the garage should be considered, because E-BoxX units are available with different construction depths depending on the conditions. Furthermore, it is necessary to decide whether the space available means that the charging point should be accessible from the front or the side.

Solution:

In most current cases, an E-BoxX from the Design-Line product line meets the requirements described in this situation. The E-BoxX can be equipped either with a fixed charging cable or, as a downgrade, with a charging socket for accommodating a pluggable cable. The Design-Line product line is limited to a maximum charging power of 16 A. However, this does meet the usual current power ranges of batteries used in the electric vehicles available on the market. Anyone who wants to be prepared for the future already can select an E-BoxX from the Industry-Line product line as an upgrade. In this case, charging powers up to 32 A (three-phase) are possible.

Description of function:

The customer plugs in his/her vehicle and the charging procedure starts immediately (type 1 plug) or after pressing a switch (type 2 plugs and sockets). The charging process is terminated by disconnecting the plug (type 1 plug) or by switching off and then disconnecting the plug (type 2 plugs and sockets).

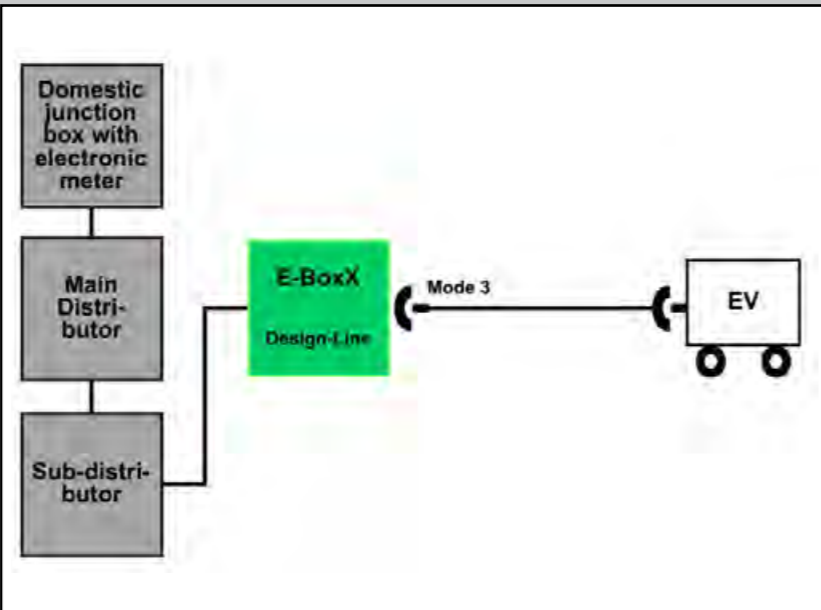

↑ upgrade

→

↓ downgrade

Product from scenario

	Industry-Line Type 2, 11 kW, LED, RCD B, IP 44, ABS 98100112, see page 75
	Design-Line Type 2, 3.7 kW, LED, RCD A, IP 44, ABS 98100103, see page 76
	Design-Line Type 2, 3.7 kW, LED, RCD A, IP 44, ABS 98100106, see page 77

Interesting features:

If a meter is required, this should be placed in the upstream installation when using Design-Line equipment. Alternatively, the meter is directly installed in the E-BoxX enclosure when the Industry-Line product line is used.

Optional products and configuration possibilities

page 92	page 92	page 80
page 92	page 93	page 78

In order to allow a better understanding of the functions described here, the fold-out page at the back of the catalogue provides corresponding explanations. Detailed product descriptions about charging stations, E-BoxX units, charging cables, etc. can be found in the corresponding chapters over the following pages.

Operator (research & development): Outside system for charging tests and data recording

Operator (research & development):
Outside system for charging tests
and data recording

Situation:

Research-oriented companies such as automobile manufacturers, universities or institutes with their own development departments and workshops are required to maintain accurate documentation of the data relating to the charging process, whether this is for simulation, research or quality assurance purposes, or else for fault analysis. This also includes accurate documentation of the general data from the test environments such as driver's name, vehicle and mileage, as well as charging-related information such as the starting and finishing times, and charging energy.

Solution:

Walther offers individual or several stand-alone stations for this purpose, preferably the VOLTANEA 600 product line, which is precisely tailored to the needs of data recording by users. Complex data recording systems can summarise both the physical data (charged kWh, time sequences, temperature, etc.) and user inputs in data records, then place these in a ring buffer in the integrated controller. The data can be called up from here at any time. Authorisation by RFID. As an upgrade, the VOLTANEA can also be equipped to be SQL-capable. As a down-grade, ECOLECTRA with touchscreen.



upgrade ↑

→

downgrade ↓

Product from scenario

VOLTANEA

M 6821 13C20 60
see page 67

VOLTANEA

M 6821 13S20 60
see page 66

ECOLECTRA

M 1521 13S30 60
see page 64

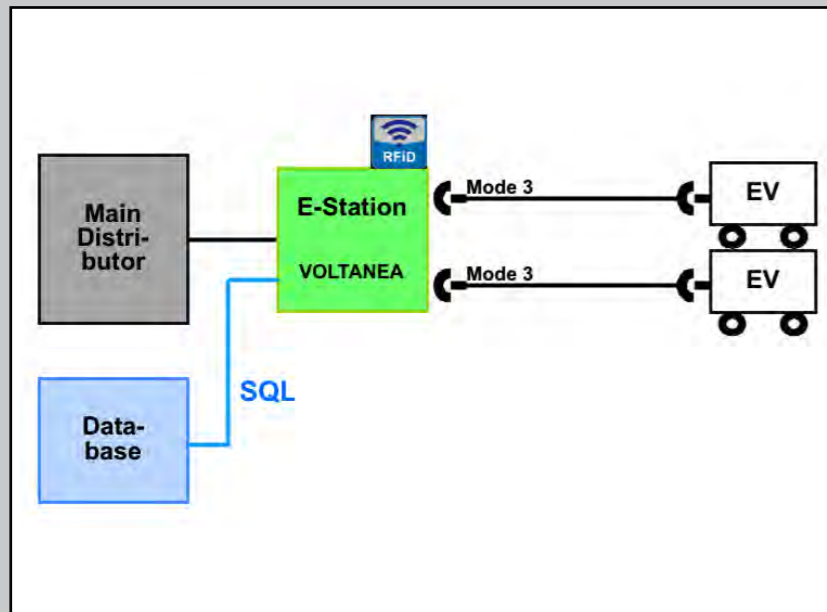

Description of function:

Generally, the user identifies himself/herself using an RFID medium or a PIN, thus creating the decisive differentiating feature in the data record. After this, it is possible for various items of data to be required in order to start the charging procedure, or to stop it subsequently.

The type of plugs and sockets used for the charging process can be configured according to the customer's requirements.

Interesting features:

The resulting charging data records can be processed further either directly in an SQL server, for example, or read out periodically. An extremely wide range of functions is available for this – from the network connection through to various Internet or mail functions.

If required, the charge controllers can be used for limiting the maximum charging current, or for specifying this current dynamically and adapting it.

In order to allow a better understanding of the functions described here, the fold-out page at the back of the catalogue provides corresponding explanations. Detailed product descriptions about charging stations, E-BoxX units, charging cables, etc. can be found in the corresponding chapters over the following pages.

Optional products and configuration possibilities



Operator (research & development): Mobile charging solution in trolley case

Operator (research & development):
Mobile charging solution in trolley case

Situation:

During development projects, a mobile and flexible use of charging possibilities is often required, especially in locations where there is a supply system with CEE sockets. This allows flexible charging at various locations without having to install a new, elaborate charging infrastructure. This situation is used, for example, in car despatch warehouses, on forecourts in front of workshops, on construction sites or in event locations.

Solution:

A complete Walther E-BoxX is integrated in a sturdy trolley case on wheels. It contains protection elements and the entire charging electronics, i.e. a Walther charge controller and type 2 charging socket. As an upgrade, it is possible for a BCD selector switch to be integrated (refer to the description under "Interesting features"). As a downgrade, Walther offers portable socket combinations made of rubber. This is a particularly compact and robust solution.

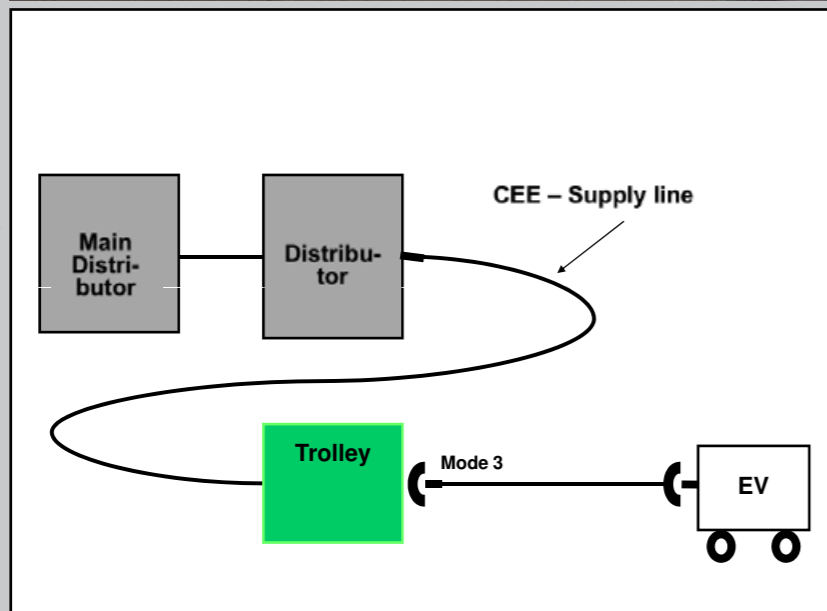

Description of function:

The trolley contains a supply cable on which a CEE plug is generally provided. The case contains electrical and electronic systems in order to carry out a complete charging procedure on the vehicle. The entire charging process is controlled by a Walther charge controller. The trolley case has a compact design, meaning that it can be transported in the luggage compartment of any vehicle.

Interesting features:

The supply cable can be adapted to an extremely wide range of plugs and sockets, as well as power supply systems. Optionally, a BCD (binary coded decimal) selector switch can be used with the charge controller to adapt the charging current

individually to the local electrical power supply and to the vehicle which is to be charged. The charging current can be set on the following levels: 10 A, 12 A, 13 A, 16 A, 20 A, 25 A, 32 A. In addition, the consumption can be measured using an optional energy meter.

In order to allow a better understanding of the functions described here, the fold-out page at the back of the catalogue provides corresponding explanations. Detailed product descriptions about charging stations, E-BoxX units, charging cables, etc. can be found in the corresponding chapters over the following pages.

Product from scenario

		Trolley 98400103 , see page 82
		Trolley 98400101 , see page 82

Optional products and configuration possibilities

 page 98	 page 98	 page 99
 page 92	 page 93	

Operator (research & development): Various solutions for charging at laboratory facilities

Operator (research & development):
Various solutions for charging
at laboratory facilities

Situation:

Frequently, individual charging points are required in workshops, laboratory halls or assembly halls in order to charge vehicles used for test purposes or belonging to customers. In this case, it is most important to have a pragmatic, easily accessible charging option. Identifications and data recordings are not taken into account in this scenario as a result. Occasionally, it is a good idea to use suspension-type combinations in order to make optimum use of limited space. In addition, the charging point should be as close as possible to the vehicle in order to avoid trip hazards due to the charging cables.

Solution:

Individual E-BoxX units from the Industry-Line represent a solution, since they are available in an extremely wide range of variants with regard to socket type, fixed spiral charging cable or socket as well as a very wide range of devices for DIN-rail mounting. As an upgrade, the E-BoxX in Industry-Line can be equipped with a BCD selector switch (see Interesting features in the „Mobile charging solutions in the trolley case“ scenario). Alternatively, suspension-type combinations are possible (downgrade). In this case, the protection elements are usually accommodated in the upstream installation, in order to keep the dimensions of the system as small as possible. A suspension-type combination is a space-

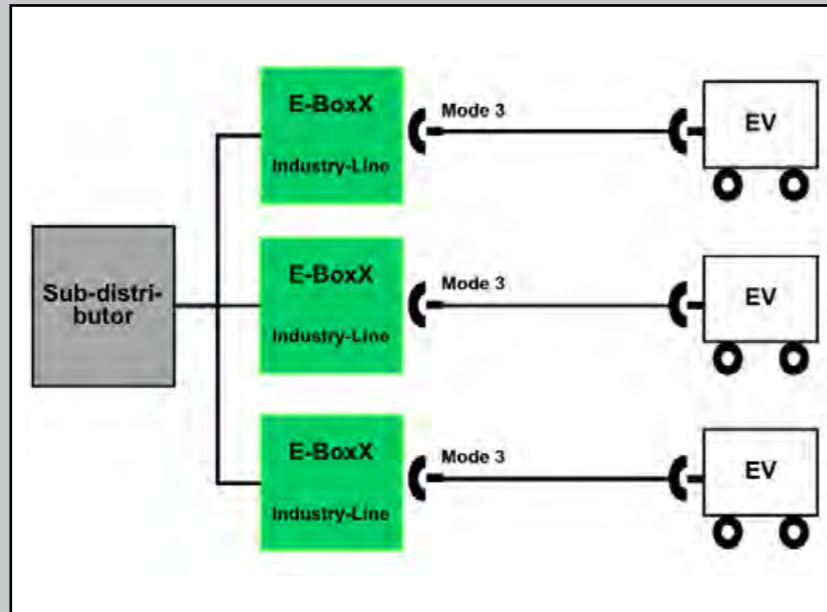

saving power supply unit for ceiling mounting. It can even include a compressed air line with quick coupling, as well as Schuko or CEE sockets.

Description of function:

The functions of the individual charging sockets are safeguarded by the Walther charge controller with the help of PWM communication – irrespective of whether type 1 or type 2 – (see chapter 8 „Accessories“). This means all commonly used electric vehicles can be charged in the AC area.

All E-BoxX units with type 1 or type 2 plugs and sockets have a switch for terminating the charging procedure, even from outside the vehicle.

Interesting features:

The E-BoxX units can be equipped with a range of additional devices according to the customer's preference – from energy meter to BCD selector switch for specifying the maximum charging current using the Walther charge controller

In order to allow a better understanding of the functions described here, the fold-out page at the back of the catalogue provides corresponding explanations. Detailed product descriptions about charging stations, E-BoxX units, charging cables, etc. can be found in the corresponding chapters over the following pages.

Product from scenario

upgrade ↑ → ↓ downgrade	 <p>Industry-Line Type 2 22 kW LED RCD B IP 44 98100115BCD see page 75</p>
	 <p>Industry-Line Type 2 22 kW LED RCD B IP 44 98100113, see page 75</p>
	 <p>Suspension-type combination Type 2 11 kW LED RCD A IP 44 98100116, see page 83</p>

Optional products and configuration possibilities

 page 92	 page 92	 page 82
 page 92	 page 93	

Operator (fleet): Complete system for charging large company fleets

Operator (fleet):
Complete system for charging large
company fleets

Situation:

Companies today have the option of switching over their field force and company vehicles to electric cars. In the short to medium term, those that do this are predominantly companies with vehicles that are driven over distances which can be covered by available electric cars (charity organisations, postal service, courier services, etc.). The scenario described here is aimed at the application involving a large fleet (> 20 vehicles). This usually requires the revision of the existing energy supply infrastructure. A charging infrastructure project thus starts with planning the energy to be provided and examining the question of when which loads occur. Once these preconditions have been clarified, it is possible to formulate the requirements on the charging infrastructure and the necessary energy management.

Solution:

Walther offers a complete solution for projects of this kind, from the transformer station and low voltage distributor (main and subdistributor) through to the charging station or E-BoxX. Walther is the only manufacturer on the market capable of supplying all the necessary products from a single source, meaning that they are optimally adapted to one another and your specific requirements. In the scenario described



here, charging stations from the ECOLECTRA product line are used, and the access release for both type 2 charging sockets is performed via RFID. As an upgrade, it is also possible to integrate a touchscreen for user interaction. The downgrade option involves an E-BoxX from the Slim-Line. In this case, the charging point is released using knob switches.

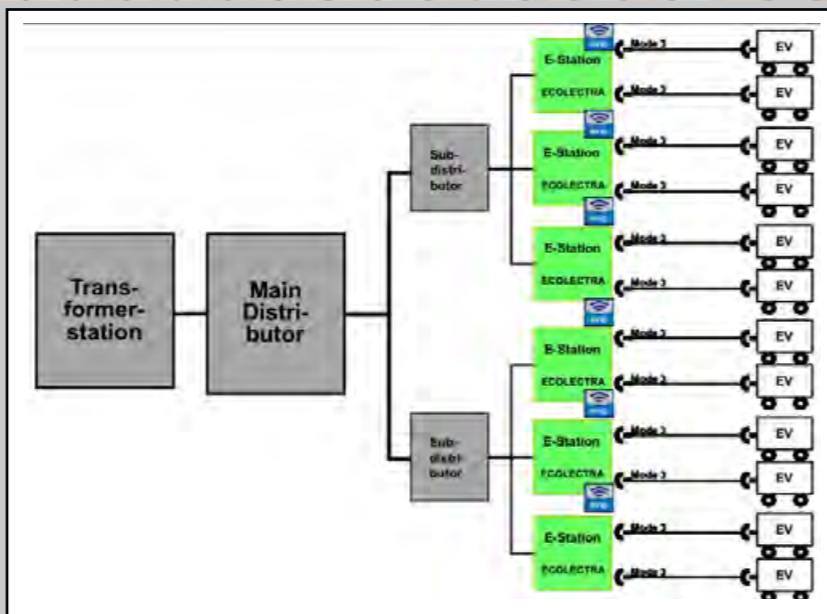

Description of function:

Employees are identified at the charging station using existing RFID cards already held by employees, (e.g. time clock cards). This allows access authorization to be controlled in a straightforward and inexpensive way. In addition, access rights can be used for restricting the access to stations to selected employees such as the Board of Management or field force employees who have charging priority, for example. In this case, the energy management system will provide a higher charging current. The charging procedure is started following identification, at the push of a button.

Interesting features:

Due to Walther's many years of experience, we are able to plan and deliver not only complete systems but also parts of systems according to customers' wishes. At the same time, our customers receive optimum support in planning and a system that is tailored to their requirements, leading to a cost-effective overall package in every case. We have already implemented customers' systems with nominal current ratings up to 1000 A.

In order to allow a better understanding of the functions described here, the fold-out page at the back of the catalogue provides corresponding explanations. Detailed product descriptions about charging stations, E-BoxX units, charging cables, etc. can be found in the corresponding chapters over the following pages.



↑ upgrade

→

↓ downgrade

Product from scenario

ECOLECTRA

M 1121 13530 60
see page 65

ECOLECTRA

M 11L1 12110 60
see page 65

Slim-Line

98200106, see page 81

Optional products and configuration possibilities

page 5

page 93

page 5

page 5

Operator (fleet): "express" charging system by colour coding

Operator (fleet):
"express" charging system by colour coding

Situation:

Especially for initial and pilot projects, there is often an adequate cost-benefit ratio required in order to promote a first entry into the field of electric mobility. Nevertheless, functions that are relevant for the application and pragmatically important, such as charging priorities, should not fall by the wayside due to this cost aspect. A small fleet, for example consisting of service vehicles or vehicles for municipal authorities and pizza delivery services, etc., do not need an extensive identification and communication process. In such cases, the emphasis is placed on a simple charging procedure, because the vehicles are in some cases used several times a day, and thus have to be charged at varying speeds according to the individual situation.

Solution:

To support projects of this kind, Walther offers a very straightforward solution at optimal cost: E-BoxX units from the Industry-Line which offer different charging currents distinguished by colour. For example, a red „express“ E-BoxX can be marked for urgent, short-notice charging requirements whereas the remaining E-BoxX units can have a different colour and be supplied with a lower charging power (simplified energy management).

Charging is started using a knob switch. As an upgrade, the E-BoxX units can be equipped with a meter. The alternative downgrade involves a fixed cable, and thus relies on upstream protection in the subdistributor. However, this scenario can basically be implemented with all E-BoxX units from Walther.

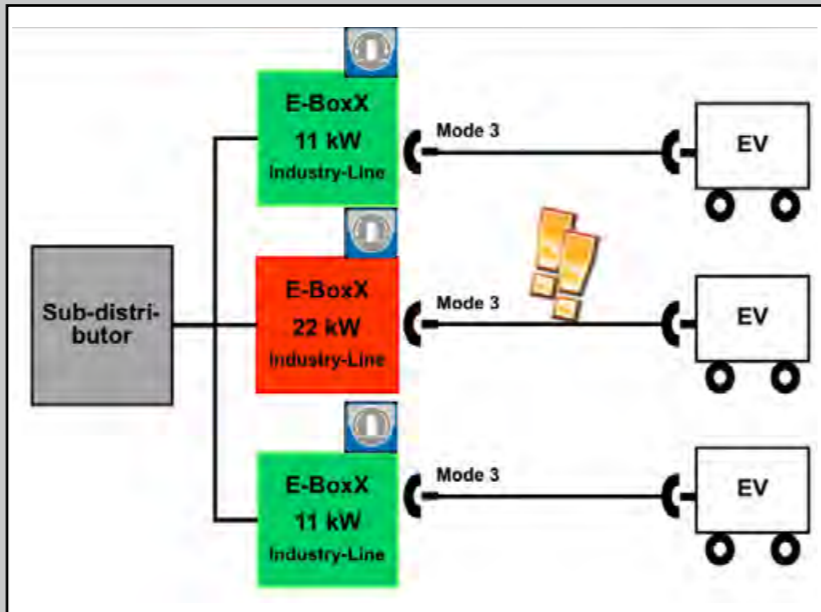

Description of function:

There is no need for employees to identify themselves at the charging stations in this semi-public area, so that individual E-BoxX units with different configurations are sufficient. On request, the most straightforward access authorization can be provided by key-operated switches, for example.

Interesting features:

Access rights for selected employees such as the Board of Management or field force employees can be granted different charging priorities. In this case, a higher charging current can be provided by the energy management.

In order to allow a better understanding of the functions described here, the fold-out page at the back of the catalogue provides corresponding explanations. Detailed product descriptions about charging stations, E-BoxX units, charging cables, etc. can be found in the corresponding chapters over the following pages.

upgrade ↑

→

downgrade ↓

Product from scenario

	Industry-Line Type 2 22 kW LED RCD B IP 44 ABS 6.9 meter RAL 98100115, see page 75
	Industry-Line Type 2 11 kW LED RCD B IP 44 ABS RAL 98100112, see page 75
	Industry-Line Type 1 3.7 kW LED RCD value IP 44 ABS 98100109, see page 74

Optional products and configuration possibilities

page 5	page 4	page 78
page 92	page 93	page 80

Operator (fleet): Satellite system with data transfer for fleet management requirements

Operator (fleet):
Satellite system with data transfer for
fleet management requirements

Situation:

Companies with larger fleets generally operate a fleet management system. This is a matter of monitoring and controlling costs and usage. As a result, data generation and data processing with the highest possible level of transparency represent basic prerequisites for the fleet manager. In addition, identification processes are required in order to allocate the data to the users as well. Furthermore, there are frequently also requirements for interaction between the charging system and driver. For example, the driver may wish to make an input for his/her vehicle to be recharged by a particular time. Central monitoring and control of energy and signals are thus essential.



Product from scenario

upgrade ↑

→

downgrade ↓

	ECOLECTRA M 15J0 10E00 60 see page 64
	Slim-Line 98200105 , see page 81
	Industry-Line 98100113 , see page 75

Solution:

In order to achieve this complex scenario, it is recommended for a so-called satellite system to be installed. In this case, a central station from the VOLTANEA 600 product line is used, with a touch-screen for identification and communication processes. The E-BoxX units in the Slim-Line series at the parking spaces are connected to this central unit, and are controlled from there. The central

unit should be positioned so that it is within sight of the E-BoxX units, thus making it possible to select the charging point (e.g. parking space no. 5). Depending on the type of configuration, the satellites can also take the form of ECOLECTRA charging stations (upgrade) or E-BoxX units from the Industry-Line product line (downgrade).

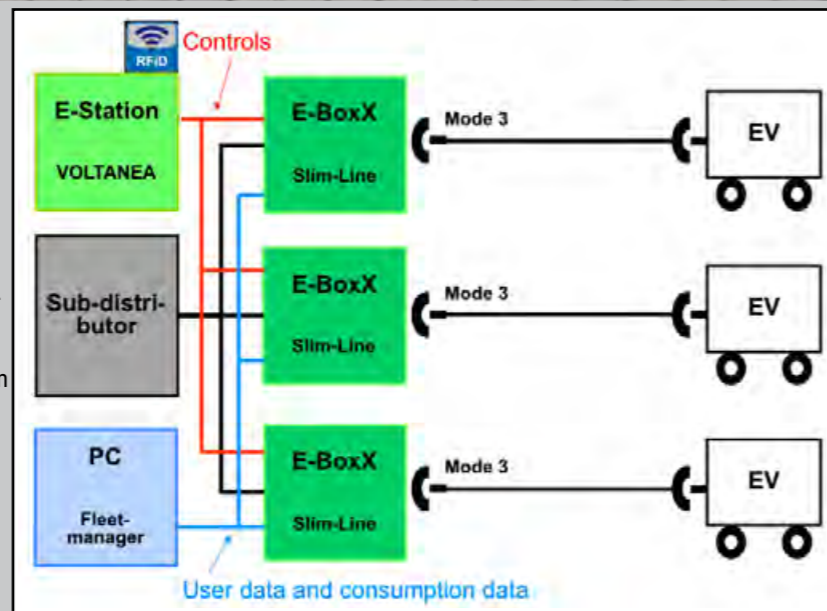

Description of function:

The users identify themselves at the central charging station by means of RFID. Following identification, the charging point is selected and any charging parameters are defined (when the vehicle will be required again, etc.). Consumption meters, date stamps and employee IDs now allow the data to be generated for the fleet manager and transferred via radio or data cable. In this case, the data format can be defined in advance by consultation so that it is provided in the necessary form for data processing in the fleet management system.

Interesting features:

Systems which monitor the corresponding parking space represent an interesting supplement, since they ensure that no vehicle will occupy a reserved parking space. To allow energy management to be implemented in larger systems, it is not just necessary to reduce the individual charging

powers if necessary, but also to shift the charging time if possible in order to adapt it to the current energy availability. For this purpose, however, it is necessary to input the required amount and the new starting time.

In order to allow a better understanding of the functions described here, the fold-out page at the back of the catalogue provides corresponding explanations. Detailed product descriptions about charging stations, E-BoxX units, charging cables, etc. can be found in the corresponding chapters over the following pages.

Optional products and configuration possibilities

page 5	page 5	page 78
page 4	page 92	

Operator (fleet): Connection of charging stations to alternative sources of energy

Operator (fleet):
Connection of charging stations to
alternative sources of energy

Situation:

Basically, electric mobility only really makes sense if the charging current used is drawn from alternative sources of energy such as solar, wind or water. Aware of corporate social responsibility (CSR) and sustainability aspects, many companies feel a certain responsibility to make a contribution to reducing consumption of energy resources. It is possible to set an example using electric mobility. Projects that are motivated by this philosophy are often implemented with small fleets (1-5 vehicles). For example, an existing or newly installed solar installation is used as the energy source, and the requirement is for a charging facility to be connected.



↑ upgrade

→

↓ downgrade

Product from scenario

	VOLTANEA Type 2 Schuko 22 kW TCP/IP RFID 6.9m -data M 6811 13B20 60 see page 67
	VOLTANEA Type 2 Schuko 22 kW TCP/IP RFID 6.9m -data M 68M1 12110 60 see page 66
	ECOLECTRA Type 2 22 kW RCD B IP 44 6.9m -data M 11J0 10E00 60 see page 65

Solution:

A central distribution cabinet from the assortment of Walther power distributors for outside areas provides the connection to the alternative power source. It is even possible to accommodate the necessary inverters here if required. A charging station from the VOLTANEA product line permits activation of both charging points using RFID. As an upgrade, it is also possible

to have a touchscreen for communication with the driver. This allows the charging parameters (required charging current, charging duration, etc.) to be requested, and thus energy management can be implemented. As a downgrade, it would be possible to use an ECOLECTRA with key-operated switch. Also, two charging points can be offered per station here.

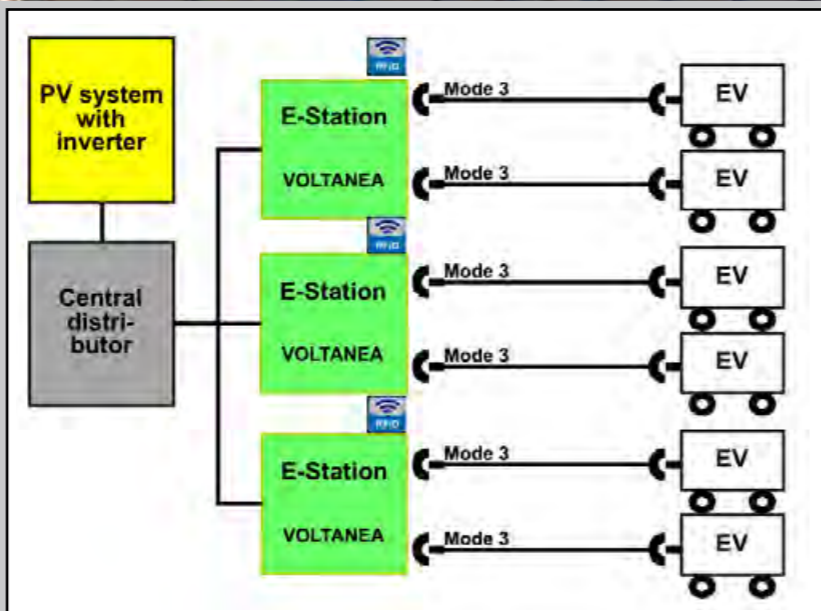

Interesting features:

The intelligent charging systems described represent a reasonable way of adapting the private contribution to energy generation by PV installations. Simple control models can be used for undertaking dynamic load management under optimum customer conditions. Here too, it is also a good idea to enter the available charging time window.

Description of function:

Employees identify themselves at the charging station using their RFID cards. Depending on the expansion stage of the charging station, the charging is now started directly or the request for charging parameters commences (upgrade, touchscreen required). Drivers who wish to collect their vehicles again must identify themselves at the charging station once again, and the charging plug that has been locked for the charging is then unlocked again, allowing the driver to pull it out.

Optional products and configuration possibilities

page 80	page 5	page 5
page 92	page 92	page 92

In order to allow a better understanding of the functions described here, the fold-out page at the back of the catalogue provides corresponding explanations. Detailed product descriptions about charging stations, E-BoxX units, charging cables, etc. can be found in the corresponding chapters over the following pages.

Operator (fleet): Representative charging systems, taking the example of a car dealership



Operator (fleet):
Representative charging systems,
taking the example of a car dealership

Situation:

The car dealership requires an easily accessible charging infrastructure for charging its electric vehicles / demonstrators. For this purpose, it is necessary to have charging points in the showroom and on the forecourt. The forecourt should be accessible to visitors, especially in the evening and on weekends, therefore it is recommended to control the access to the charging station by a key-operated switch. This means the operator has total control over when to allow access to the charging station.

Solution:

For the outside area, Walther recommends using a charging station from the ECOLECTRA product line with a touchscreen. This solution has a representative appearance, and can be designed according to the dealership's CI. Using the touchscreen, the dealership can show product presentations, event dates or other customer information. As an upgrade, a VOLTANEA charging station with RFID identification and TCP/IP can be used for network connection, also containing two Schuko sockets as well as the two type 2 charging sockets. As a downgrade, it would



be possible to use an ECOLECTRA with key-operated switches without touchscreen. The charging points in the showroom can be implemented as cost-effective Industry-Line or Design-Slim-Line units, depending on what the dealership's objective is (simple charging vs. product presentation via E-BoxX to customers). A further alternative would be a portable rubber combination that can be used for charging a vehicle as required.

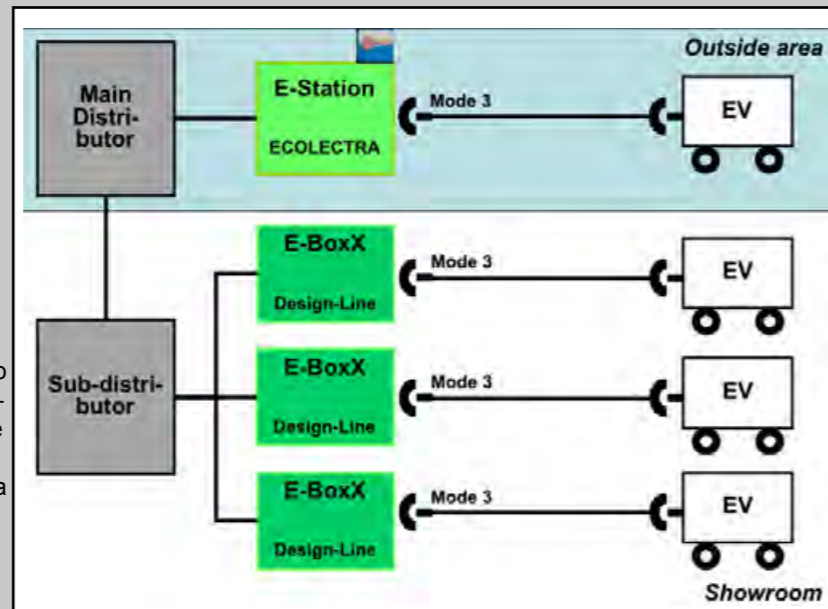

Description of function:

The charging station is activated by touchscreen and localPIN. This allows the dealership's demonstrators and service vehicles to be charged during the day. As the outside area should occasionally be accessible to visitors on the weekend, the access can thus be controlled easily. In most cases, there is no need for identification, communication and data management, although they are basically feasible at any time. The charging station in the outside area can be equipped with a display, for example, allowing slideshows or presentations (campaigns, product presentations, etc.) by the dealership to be displayed on the weekend. Refer to chapter 7 „Marketing / added-value services“ for more information.

Interesting features:

It is also possible to operate the station with coins or tokens, in which case already existing tokens can be used, such as those for operating high-pressure washers or vacuum cleaners. The workshop and the installer can decide whether the required RCD (residual current device) or the circuit breaker will be installed in the charging

device, or whether they can be accommodated in the upstream installation.

Before the charging devices are installed, it is essential for the electrical installation to be thoroughly checked by the installer. This avoids problems in the overall installation, e.g. due to "AC/DC sensitive" RCDs (residual current devices).

In order to allow a better understanding of the functions described here, the fold-out page at the back of the catalogue provides corresponding explanations. Detailed product descriptions about charging stations, E-BoxX units, charging cables, etc. can be found in the corresponding chapters over the following pages.

Product from scenario

upgrade ↑



VOLTANEA
Type 2 Schuko 22 kW
TCP/IP RFID
M 6821 13520 60
see page 66

→



ECOLECTRA
Type 2 Schuko 22 kW
L PIN IP 44
M 1511 13A30 60
see page 64

downgrade ↓



ECOLECTRA
Type 2 Schuko 22 kW
M 15J0 10E00 60
see page 64

Optional products and configuration possibilities



page 5

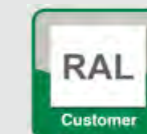

page 5



page 5

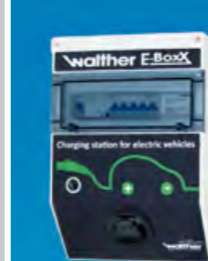

page 74



page 80



page 83

Operator (fleet): Charging the company's own electric car and visitors' vehicles

Operator (fleet):
Charging the company's own electric car and visitors' vehicles

Situation:

If a company is planning to purchase only one or a few electric vehicles for its own purposes (e.g. small business trips in the immediate vicinity, visits to customers, delivering packages, etc.) or wants to provide a charging possibility for customers and visitors, it is recommended for an E-BoxX with simple release by key-operated switch to be installed. Depending on the space available, the E-BoxX must be mounted on a wall or set up in the open area.



↑ upgrade

→

↓ downgrade

Product from scenario

ECOLECTRA

M 15J0 10E00 60,
see page 64

Industry-Line

98100113 + 620 WL82ET
see page 75

Industry-Line

98100113, see page 75

Optional products and configuration possibilities



page 5



page 4



page 5



page 78



page 80

Solution:

In this scenario, it is assumed that the E-BoxX is going to be set up in the open area. Therefore, it is recommended that an E-BoxX from the Industry-Line product line should be used, and be mounted on a painted stainless steel post. The charging point is released using a key-operated or knob switch. The E-BoxX is equipped with a type 2 socket and, as an alternative, also a Schuko socket for charging according to mode 2. In addition to electric cars, it is also possible to recharge scooters, e-Bikes or pedelecs using the Schuko socket.

The upgrade in this case represents a charging station in the ECOLECTRA product line with identical functions, but a more representative appearance. The downgrade is an E-BoxX from the Industry-Line product line without a stainless steel post, for wall mounting.

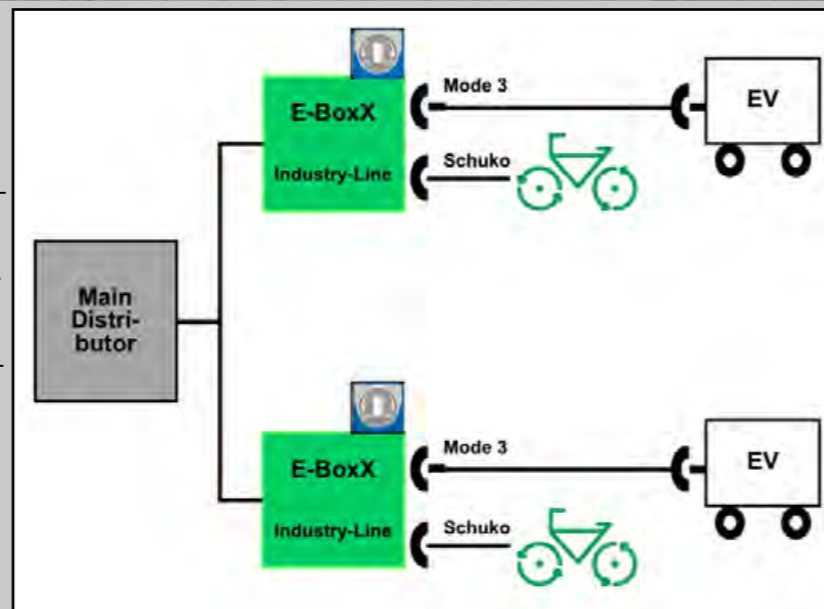

Description of function:

The required socket or charging point is switched as required using a key-operated switch or knob switch. The key can be withdrawn from the key-operated switch in both positions (on and off), allowing it to be kept at the reception for customers' use, for example. This avoids misuse.

Interesting features:

If the charging facility should be made more representative or equipped with more extensive identification processes, it is generally necessary to use a charging station instead.

In order to allow a better understanding of the functions described here, the fold-out page at the back of the catalogue provides corresponding explanations. Detailed product descriptions about charging stations, E-BoxX units, charging cables, etc. can be found in the corresponding chapters over the following pages.

Operator (fleet): Equipping a modern, comprehensive housing project with charging points



Operator (fleet):
Equipping a modern, comprehensive housing project with charging points

Situation:

Many new building projects, especially involving larger residential buildings, currently consider integrating charging possibilities for electric vehicles. In this way, the building owners are facing up to future requirements and developments by offering comprehensive dwelling and mobility concepts. Most of these projects pursue futuristic design approaches, as a result of which corresponding levels of design and equipment are required in the charging facilities offered. The charging points are predominantly installed in underground garages. Frequently, additional charging facilities are provided in the outside area, with restricted access.



upgrade ↑

→

downgrade ↓

Product from scenario

	ECOLECTRA Type 2 Schuko 22 kW RFID IP 44 M 1521 13530 60 see page 64
	ECOLECTRA Type 2 22 kW RFID RCD B IP 44 M 11L1 12110 60 see page 65
	ECOLECTRA Type 2 22 kW LED RCD B IP 44 M 11J0 10E00 60 see page 65

Solution:

A charging station from the ECOLECTRA product line can be used in the outside area. This offers adequate space for identification and communication functions. The charging station has an RFID card reader for identification and thus release of the two type 2 charging sockets. As an upgrade, the charging station can also be equipped with a touchscreen for requesting charging parameters (charging current, charging time, etc.). In the downgrade, activation of the charging socket is handled using a key-operated switch.

is ideally suited for installation in an underground garage. Identification and communication can be organised on a centralised or decentralised basis, depending on the particular requirements for authorisation and energy settlement. For example, the E-BoxX can be connected directly to the meters of the corresponding tenants. In this case, it makes sense for the charging socket to be activated using key-operated switches. Alternatively, identification and settlement is also possible using a central station (VOLTANEA 600) with a satellite system comprising E-BoxX units.

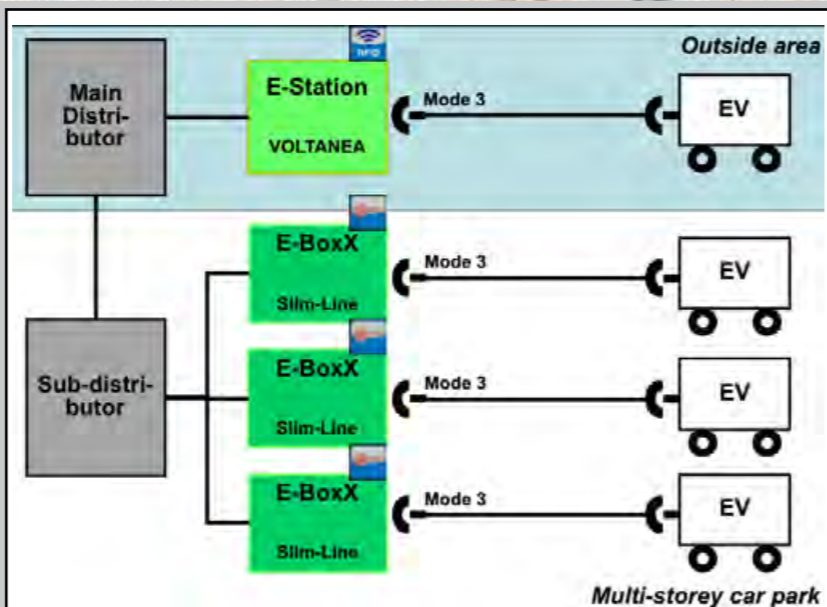

Description of function:

In the outside area, the driver activates the charging station using an RFID chip or key-operated switch, depending on the configuration of the charging station. The release in the underground garage is performed using a key-operated switch on the E-BoxX in the decentralised solution. As soon as the charging cable is plugged in, the charging procedure is started with a key. This key can then be withdrawn again immediately. In a central solution, identification and release are handled on a touchscreen of a VOLTANEA 600.

Interesting features:

It is also possible for charging stations from the ECOLECTRA 320 plus series to be used for service vehicles of the operators or for a separate group of users at special, additional parking spaces. This reduces the walking distances for users. Also, a Schuko socket can be integrated into the charging station, for example to

operate implements such as blower vacs, high-pressure washers, etc. Furthermore, E-BoxX units from the Design-Line with fixed cables can be used for improving utilisation convenience further, especially in representative structures.

Optional products and configuration possibilities

page 5	page 5	page 4
page 76	page 74	page 78

In order to allow a better understanding of the functions described here, the fold-out page at the back of the catalogue provides corresponding explanations. Detailed product descriptions about charging stations, E-BoxX units, charging cables, etc. can be found in the corresponding chapters over the following pages.

Operator (marketing): Charging station on customer's car park as a marketing instrument with additional benefit

Situation:

The E-Mobility application area offers companies an interesting possibility of undertaking their own image marketing. "Green" companies and appropriately perceived activities are increasingly playing a part in purchase decisions and the associated brand loyalty. The provision of charging facilities in customer car parks indicates that companies are committed to sustainability issues. In addition, these charging stations can also generate a second benefit by publicity surfaces and integrated, interactive screens. The company can show small publicity slideshows here, or present product information.



Solution:

The combination of marketing and second benefit as described in this scenario can be achieved with a VOLTANEA 600 charging station. Appealing foil stickers on the charging station as well as integration of a touchscreen monitor (5.7 inch) can generate an optimum level of attention (eye-catcher) amongst end-users. Optionally, it is also possible to place an illuminated sign on the roof of the charging station. If a larger touchscreen should be used, it is possible to move up to a charging station in

the AMPERA 800 product line (upgrade). This allows the product information and publicity films of the operator to be presented even more effectively. An ECOLECTRA can be used as a downgrade. Here too, it is possible to integrate a touchscreen. However, the station is somewhat less obtrusive, because of its smaller size.

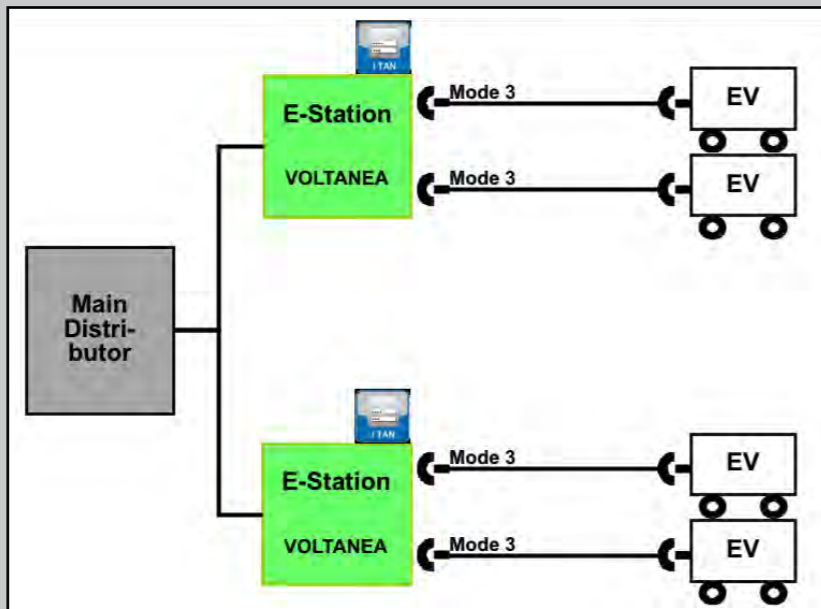

Description of function:

The charging points can be released in several ways. For example, a TAN code can be generated for the release whilst shopping at the checkout. This can then be used for charging on the customer's next visit, by entering the code to activate the charging socket via the touchscreen.



upgrade ↑

→

downgrade ↓

Operator (marketing):
Charging station on customer's car park as a marketing instrument with additional benefit

Product from scenario



AMPEREA
Type 2 Schuko 22 kW RFID
L PIN abc RCD B DAB
large screen on request, see page 68



VOLTANEA
Type 2 Schuko 22 kW RFID
L PIN abc
6.9 meter -data RCD B
M 6821 13520 60
see page 66



ECOLECTRA
Type 2 Schuko 22 kW RFID
L PIN abc RAL
M 1521 13530 60
see page 64

Interesting features:

If a modern touchscreen monitor is used, it generally has its own operating system (Windows, Linux) and several interfaces. This means – depending on the resolution – it is also possible to play high-quality videos, etc. if required.

In order to allow a better understanding of the functions described here, the fold-out page at the back of the catalogue provides corresponding explanations. Detailed product descriptions about charging stations, E-BoxX units, charging cables, etc. can be found in the corresponding chapters over the following pages.

Optional products and configuration possibilities



page 5



page 5

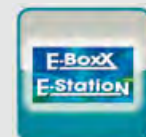

page 5



page 5

Operator (marketing): Free charging possibility on customers' car parks, taking the example of the electrical wholesale trade

Operator (marketing):
Free charging possibility on customers' car parks, taking the example of the electrical wholesale trade

Situation:

A range of companies with high customer footfall, such as electrical wholesalers, often require straightforward and cost-effective charging station solutions for their own vehicles. The logical next step is to offer the occasional customer who uses an electric vehicle the possibility of charging via a corresponding charging point. Normally, this is motivated by a desire to improve the company's profile and boost customer loyalty, so that no complicated settlement systems are required. In addition, electric mobility represents a very interesting line of business for wholesalers, and one in which companies can present and position themselves right at the outset.



↑ upgrade

→

↓ downgrade

Product from scenario

	ECOLECTRA Type 2 Schuko 22 kW RFID IP 44 M 1521 13530 60 see page 64
	ECOLECTRA Type 2 Schuko 22 kW L PIN IP 44 M 1511 13A30 60 see page 64
	ECOLECTRA Type 2 Schuko 22 kW RFID IP 44 M 15J0 10E00 60 see page 64

Solution:

The charging station recommended here from the ECOLECTRA product line is equipped with a touchscreen. Entering a local PIN releases the charging procedure following a check. As an upgrade, the ECOLECTRA could also be expanded with an RFID reader. In addition, the charging station can accommodate a touchscreen which can be used not only for activating the charging points but also for product and publicity

information by the operator. This delivers multiple benefits from the operator's perspective. As a downgrade, the charging station can be released using a key-operated switch. This allows each user to start charging his/her vehicle directly.

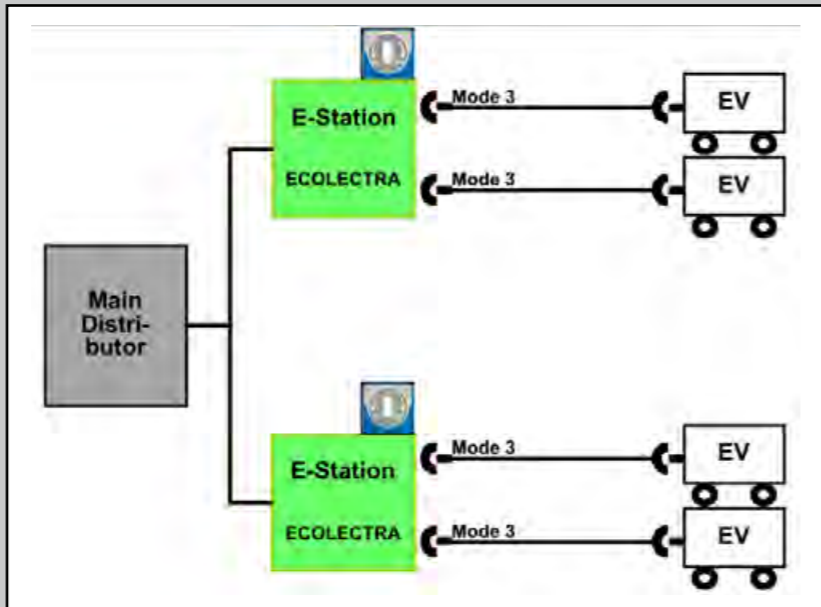

Description of function:

Once the required socket has been selected by the user, it is activated using the key or knob switch, or else via RFID depending on the configuration of the charging station. The key can be withdrawn from the key-operated switch in both positions (on and off). If the charging station is additionally used with a touchscreen, it is possible to upload the files desired for product and publicity information using an SD card reader.

Interesting features:

It would also be simple to implement a solution in which the customer receives a TAN code at the cash desk, thus allowing him/her to activate a charging point for a specific period of time. This could also be done as part of special campaigns for customer loyalty or sales control. This TAN can then be redeemed using the touchscreen during the activation dialogue.

In order to allow a better understanding of the functions described here, the fold-out page at the back of the catalogue provides corresponding explanations. Detailed product descriptions about charging stations, E-BoxX units, charging cables, etc. can be found in the corresponding chapters over the following pages.

Optional products and configuration possibilities

page 5	page 5	page 5
page 66	page 80	

Operator (marketing): Charging possibilities for electric bikes, taking the example of restaurants/hotels

Operator (marketing):
Charging possibilities for electric bikes,
taking the example of restaurants/hotels

Situation:

The market for electric bicycles has now already become a mass market. Every year, about 500,000 e-Bikes / pedelecs are sold, and the entire market consists of several million bicycles. As well as with older people, e-Bikes are now also increasingly being bought by people in the middle-age. This market offers restaurant owners and hoteliers a good opportunity to present themselves as environmentally friendly and customer-oriented. Whilst customers are enjoying the beer garden or taking lunch in the restaurant, their bicycles' batteries can be charged in enclosures comprising lockable cabinets, referred to as pedelec cabinets. Pedelec cabinets are being used more and more frequently, especially on cycle trails.

Solution:

The pedelec cabinets developed by Walther each have a Schuko socket in each lockable compartment. The compartments can be released or locked using a coin payment system. The upgrade to the quadruple cabinet is a sextuple cabinet, in which authorisation can be performed using RFID. Both variants are also equipped with a so-called DJB (domestic junction box).

socket combinations, thus representing a highly pragmatic solution. These socket strips are standard articles from the Walther CEE socket combination range. If required, simply talk to us or your electrical wholesaler directly.

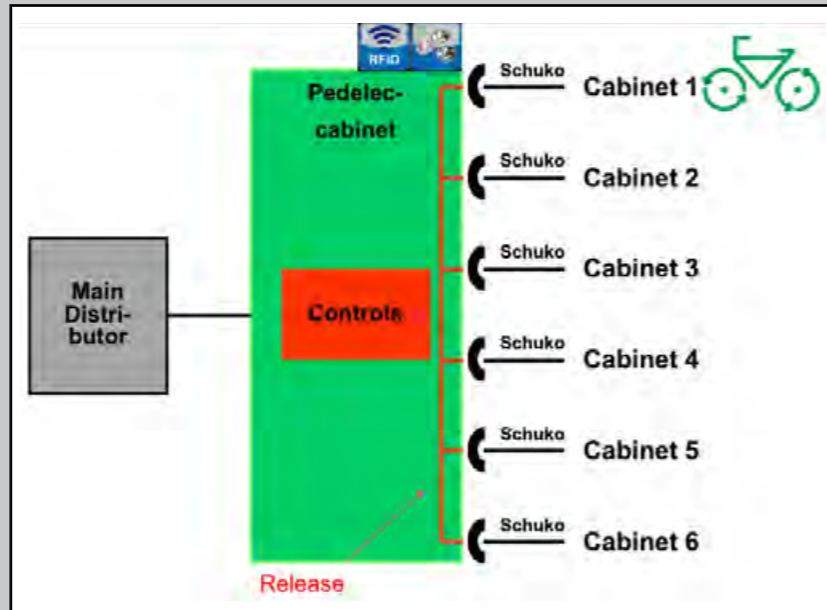

Description of function:

Pedelec cabinets are designed so that the customers can place their helmets, backpacks and other objects in the compartments, whilst the batteries are being charged at the Schuko sockets. All compartments are individually lockable. The compartments can be locked and the Schuko sockets subsequently released by different methods: deposit tokens / coins, RFID, etc. In this case, the operator has many individual possibilities depending on what form of charging service should be offered to the customers.

Interesting features:

Pedelec cabinets can also be powered from alternative energy sources by installing solar panels or wind turbines on the cabinet roof.

In order to allow a better understanding of the functions described here, the fold-out page at the back of the catalogue provides corresponding explanations. Detailed product descriptions about charging stations, E-BoxX units, charging cables, etc. can be found in the corresponding chapters over the following pages.



upgrade ↑



Product from scenario



Sextuple Pedelec cabinet
Schuko RFID LED
RCDA DJB InMeter
RAL
M CD90 2290 40
see page 84



Quadruple Pedelec cabinet
Schuko LED
RCDA DJB InMeter
RAL
M BEP0 1210 40
see page 84

Optional products and configuration possibilities



page 5

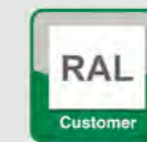

page 5

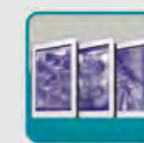
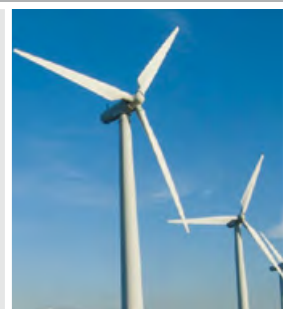

page 5

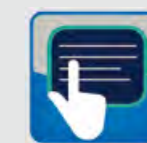

page 5



Operator (marketing): Employees' car park with E-BoxX units on a post system

Operator (marketing):
Employees' car park with E-BoxX units on a post system

Situation:

In Germany, there is an ever increasing scarcity of qualified specialists. This means companies are faced with the challenge of increasing their employee marketing. On the one hand, it is important for companies to present themselves as modern and sustainable, whilst on the other hand companies would like to underscore their employee orientation by offering certain services. It is particularly in innovative sectors such as renewable energies, media or IT that employees frequently represent pioneers in the use of technological innovations. It is expected that there will be a tendency towards a higher density of electric vehicles. This scenario describes a simple entry to provision of charging possibilities for a company's own employees.



Solution:

E-BoxX units with toggle or key-operated switches can be used as the most cost-effective and open charging system. In particular, Walther E-BoxX units from the Industry-Line product line are suitable for this, because they can be installed in the outside area on a stainless steel post. An energy management is normally not required, because often only a small number of charging facilities are provided, and the charging of vehi-

cles is usually distributed over the working day without priorities. As an upgrade, it is possible to use an E-BoxX from the Slim-Line product line with key-operated switch. The downgrade is an Industry-Line with knob switch. These two options assume wall mounting.

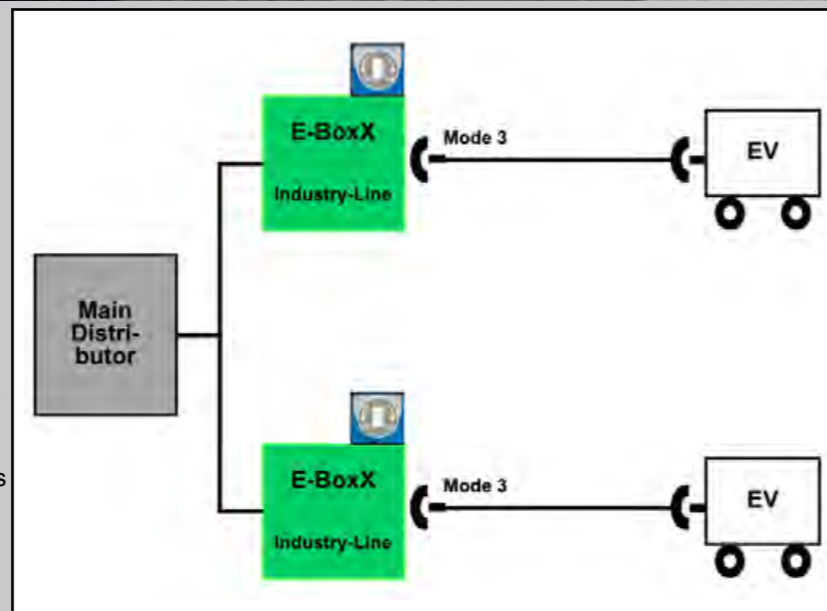

Description of function:

The employee inserts the vehicle's charging cable into the corresponding charging socket at the start of the working day. Charging is started using a knob switch. When, at the end of the day, the vehicle is required for the journey home, the charging procedure is then terminated by the knob switch and the charging cable can be disconnected. Optionally, it is possible to install meters for consumption recording in each E-BoxX, or in the upstream distribution system.

Interesting features:

Walther also offers suitable installation permits, and the customer requires it, the necessary devices for DIN-rail mounting (fuses, circuit breakers, meters, RCDs (residual current devices), etc.) can also be installed in the upstream distribution system. The IP rating of the E-BoxX units is sufficient for this purpose in any event. If the existing

In order to allow a better understanding of the functions described here, the fold-out page at the back of the catalogue provides corresponding explanations. Detailed product descriptions about charging stations, E-BoxX units, charging cables, etc. can be found in the corresponding chapters over the following pages.

upgrade ↑

→

downgrade ↓

Product from scenario

	Slim-Line Type 2, 22 kW, LED, RCD B, 6.9 meter, ABS, RAL 98200106, see page 81
	Industry-Line Type 2, 22 kW, LED, RCD B, IP 44, ABS, RAL 98100113 + 620 WL 82 ET see page 75
	Industry-Line Type 2, 22 kW, LED, RCD B, IP 44, ABS, RAL 98100113, see page 75

Optional products and configuration possibilities

page 5	page 5	page 64
page 92	page 93	page 78

Operator (business model): Flexible, decentralised billing solution for utilities (own fleet and customers)

Operator (business model):
Flexible, decentralised billing solution
for utilities (own fleet and customers)

Situation:

Frequently, decentralised solutions are considered as an alternative to the scenario described on the following page, „Central settlement solution via online IT system with secure protocol (OCPP)“. In this case, all necessary data should be available locally at the charging station, and the user and consumption data will only be transferred periodically to the operator or provider. This reduces the operating costs of the charging station considerably, because it operates predominantly offline rather than online as in the following scenario. In addition, a combination of handling different user groups should be seen as a supplement to this. These are, firstly, the company's own service employees who want to charge their vehicles, and secondly the operator's customers. Access and data recording should be subjected to different rules by means of the identification process.

Solution:

The AMPEREA 800 product line offers a solution to this, establishing the necessary preconditions for the requirements set, above all when a domestic junction box (DJB) is required. If this is not the case, it is recommended for a charging station from the VOLTANEA product line to be used (downgrade). In both cases, these stations can be used both as stand-alone stations or as a central



unit in a satellite system. In a satellite system, additional charging points are connected to the central unit, in this case they are E-BoxX units from the Slim-Line product line. The central unit handles identification and communication with the user, and then controls the E-BoxX units accordingly. The server connection can be hard-wired using TCP/IP or, as an upgrade, wireless, depending on the customer's requirement.

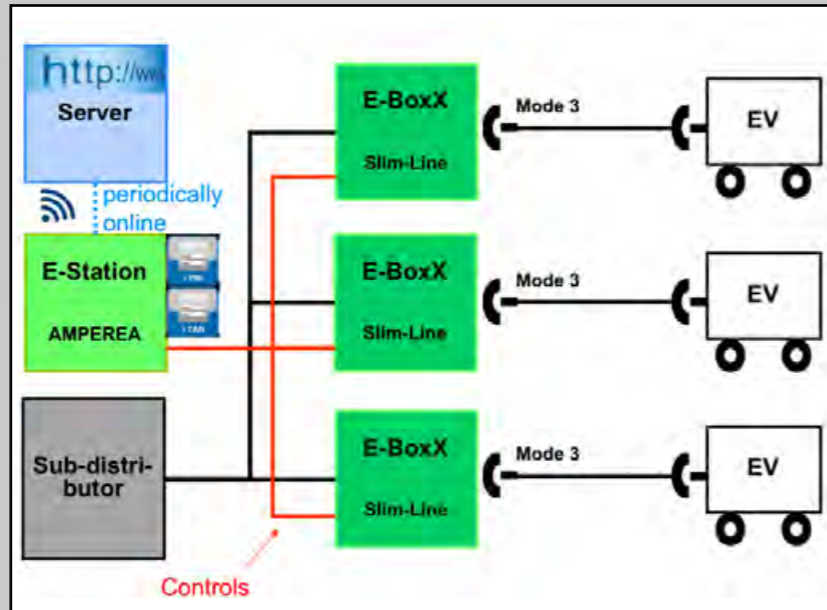

Description of function:

Dialogue with the user is via the touchscreen monitor of the charging station. There is no need for a permanent connection to a central system (backend), the memories for the central communication structures are located in the charging station: authorisation (white list), charging data records, energy management, etc. Periodic or permanent readout of the charging data records takes place via a network connection.

Identification is usually via RFID and/or localTAN. In order to enable a cost-effective customer billing, it is also possible to have a coin payment system.



upgrade ↑

downgrade ↓

Product from scenario



AMPEREA
Type 2 Schuko 22 kW DJB
OCPP RFID
6.9 kWh
MySQL
M 2821 23C20 60
see page 69



AMPEREA
Type 2 Schuko 22 kW DJB
TCP/IP RFID
6.9 kWh
M 2821 23520 60
see page 68



VOLTANEA
Type 2 Schuko 22 kW
TCP/IP RFID
6.9 kWh
M 6821 13520 60
see page 66

Interesting features:

Systems also function in regional structures via networks in cooperation with IT systems, e.g. in the form of SQL servers. This means there is no longer any obstacle to processing significant data quantities. They thus represent a mixture of straightforward online and offline systems.

In order to allow a better understanding of the functions described here, the fold-out page at the back of the catalogue provides corresponding explanations. Detailed product descriptions about charging stations, E-BoxX units, charging cables, etc. can be found in the corresponding chapters over the following pages.

Optional products and configuration possibilities



page 98



page 78



page 80



page 5

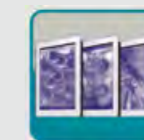

page 5



page 5

Operator (business model): Central billing solution via online IT system with secure protocol (OCPP)

Operator (business model):
Central billing solution via online
IT system with secure protocol (OCPP)

Situation:

Specifically utilities, but also other operators of charging stations, wish to charge their customers for the electricity consumed, or else to impose a flat-rate payment for use of their charging infrastructure. There are various basic requirements for this, concerning how the utilisation or consumption should be settled, as well as how the requisite data should be stored and transferred. The scenario described here is intended for charging station operators which use secure data transfer in online mode, and thus wish to manage data centrally and in real time for user groups, authorisation and settlement. One alternative in this case concerns integrating a provider such as a mobile phone operator which invoices customers using existing systems, and passes on the revenues to the charging station operator.

Solution:

The Walther AMPEREA product line is ideal for these demanding requirements due to the large amount of space it offers. For example, the AMPEREA offers space for a connection acc. to the special requirements to the energy supplier with DJB, meter space even for Ferraris meters, SLS switches and the necessary communication system as well as for the large number of electrical and electronic components required.

If no such connection is necessary, it is preferable for a station from the VOLTANEA product line to be used. In the upgrade with an AMPEREA, data transfer can also take place wirelessly via a GSM module.



upgrade ↑

→

downgrade ↓

Product from scenario

	AMPEREA M 2811 23D20 60 see page 69
	AMPEREA M 2821 23C20 60 see page 69
	VOLTANEA M 6821 13C20 60 see page 67

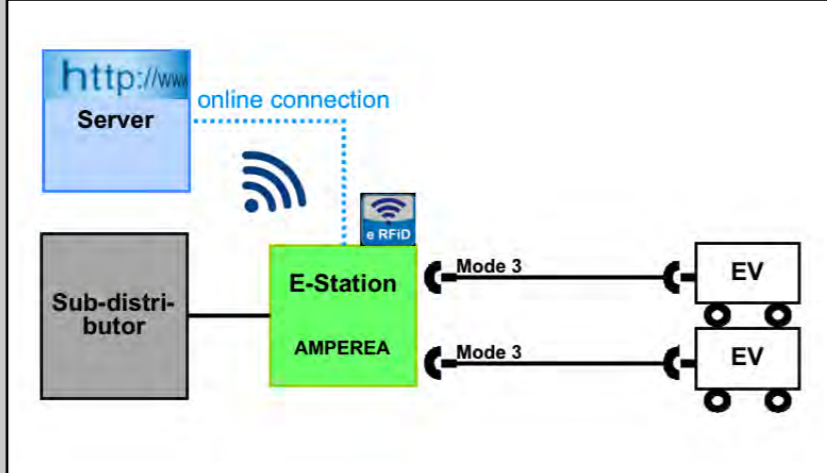

Description of function:

Dialogue with the user is via the touchscreen monitor of the charging station. A connection to a central IT system (backend) via a secure protocol (OCPP) or VPN is used for data communication. This allows data such as authorisation (white list and black list), settlement (consumption), status handling, reservation, dynamic tariff design and energy management to be managed centrally.

As a result, large quantities of data and high numbers of customers can be processed efficiently, either by the operator or a service provider which can handle the entire settlement procedure with the customers.

Interesting features:

A high level of security in data transmission is achieved by special processes and the corresponding selected hardware (modems, cards, etc.).

A characteristic feature of these processes is the need to remain constantly online with the station. Offline operation only contains auxiliary and shut-down routines, and is not possible over a longer period of time.

In order to allow a better understanding of the functions described here, the fold-out page at the back of the catalogue provides corresponding explanations. Detailed product descriptions about charging stations, E-BoxX units, charging cables, etc. can be found in the corresponding chapters over the following pages.

Optional products and configuration possibilities

page 5	page 5	page 5

Operator (business model): LocalTAN process via SMS communication with the charging station

Operator (business model):
LocalTAN process via SMS communication with the charging station

Product from scenario

Situation:

A regular topic in planning charging infrastructure products with a business model approach concerns the identification and activation of charging points by mobile phone SMS messages. In this case, the registered user shall communicate directly with the charging station for authorisation, and consumption information shall be sent to the user via SMS, as well as in the form of a processable data record to the operator for billing.

Alternatively to this "localTAN" solution, it is also possible to link up to an existing billing system in order to use the "extendedTAN process via SMS communication with the provider" scenario.



AMPEREA

- Type 2
- Schuko
- 32 kW
- LTAN
- RCD B
- DJB
- Smart

M 2811 23B20 60
see page 68

VOLTANEA

- Type 2
- Schuko
- 32 kW
- LTAN
- RCD B
- IP 44
- Smart

M 6811 13B20 60
see page 67



Solution:

The Walther AMPEREA 800 product line is ideal for this multiple requirement because of the high amount of space it offers. For example, the AMPEREA 800 offers space for a connection acc. to the special requirements to the energy supplier with DJB, meter space even for Ferraris meters, SLS switches and the necessary communication system (GSM module), and equally for the large number of electrical and electronic

components necessary. If no such connection is required, it is preferable for a station from the VOLTANEA 600 product line to be used (downgrade), which has the same technical configuration.

There is no need for an upgrade as a result of the general conditions described in the situation.

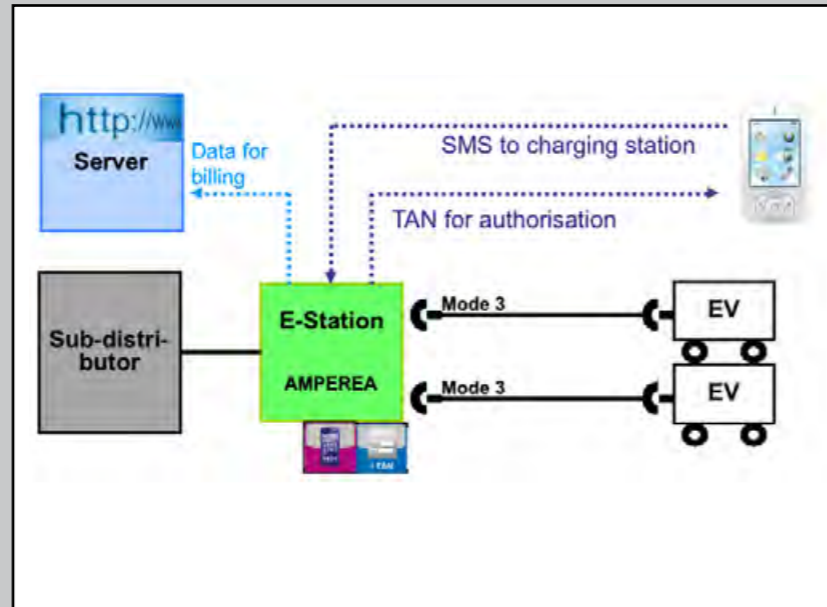

Interesting features:

RFID systems are also popular when it comes to small customer or employee groups, but nevertheless in comparison the localTAN system is frequently revealed to be the better option in spite of the slightly higher operating costs due to the mobile phone card in the charging station. This is because

the data records are sent via e-mail, allowing this information to be processed further without difficulty – irrespective of whether the process data is to be used for invoicing or just observed.

It can also be easily combined with other identification systems or payment systems.

Optional products and configuration possibilities

page 5 page 5 page 5

In order to allow a better understanding of the functions described here, the fold-out page at the back of the catalogue provides corresponding explanations. Detailed product descriptions about charging stations, E-BoxX units, charging cables, etc. can be found in the corresponding chapters over the following pages.

Operator (business model): ExtendedTAN process via SMS communication with the provider

Operator (business model):
ExtendedTAN process via SMS
communication with the provider

Situation:

Various business models in the area of charging infrastructure are based on the use of pre-existing processes for consumption billing. Preexisting and registered user groups as well as established billing structures should be used, such as in the example of the „Handyticket“ (see note below). The objective in this case is to minimise operating costs of the charging station and the transfer of consumption data from the operator's perspective, by transferring the transaction costs to the user as far as possible. In this way, billing processes can be made flexible and cost-effective.

As an alternative to this „extendedTAN“ solution, it is also possible to implement a localTAN model. Compare this to the scenario „localTAN process via SMS communication with the charging station“.

Note: Handyticket is a service by means of which registered users can purchase their tickets conveniently by mobile phone.

number for authorisation once the charging conditions of the user have been obtained via the touchscreen. Expensive GSM modules are not necessary in this solution. If a domestic junction box is needed due to the connection requirements, it is possible to use an AMPEREA charging station with the same functions as an upgrade. As a downgrade, comparable requirements can also be met using an ECOLECTRA with touchscreen.

Solution:

Walther recommends a charging station from the VOLTANEA product line as the solution model for this scenario. In this case too, sufficient space must be provided for the necessary control system and touchscreen for interaction with the user, as well as for the protection elements. The integrated TAN generator supplies the administration



upgrade ↑

→

downgrade ↓

Product from scenario



AMPEREA
Type 2 Schuko 22 kW
eTAN
M 2811 23D20 60
see page 68



VOLTANEA
Type 2 Schuko 22 kW
eTAN
M 6811 13D20 60
see page 66



ECOLECTRA
Type 2 Schuko 22 kW
eTAN
M 1511 11D30 60
see page 64

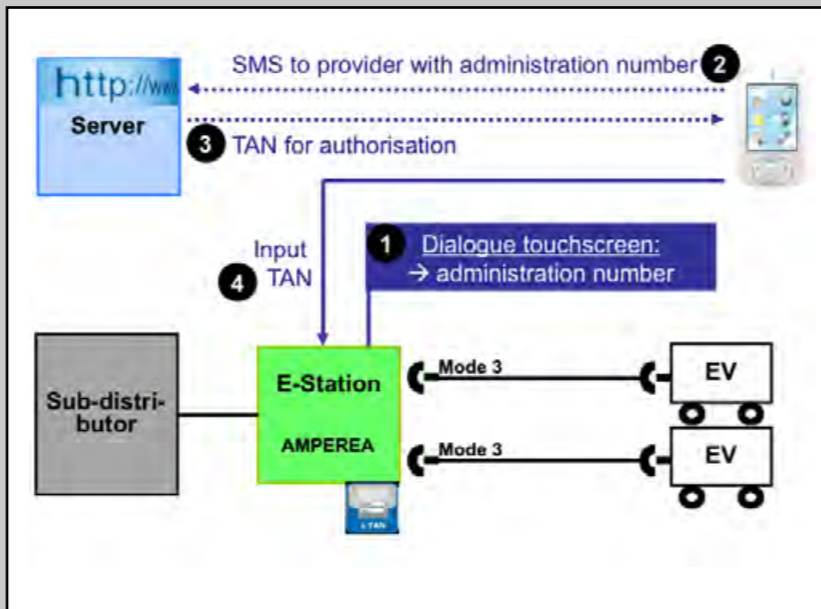

Description of function:

In the extendedTAN system, the customer selects the socket and charging time or tariff at the station and, as a result of this dialogue, receives an administration number generated by a "TAN generator" in the charging station, in a procedure which involves a complicated mathematical algorithm. The customer sends this administration number to a provider as an SMS (e.g. as a registered customer with Handyticket), and receives an SMS with a TAN in return following examination. Once this has been entered on the touchscreen monitor, the corresponding socket is released for the required time. At the same time, the customer's mobile phone account is charged with the corresponding amount.

Interesting features:

It is a feature of this process that the charging station always operates in offline mode. The entire communication with the backend takes place between the customer and provider. This saves significant operating and communication costs for the charging station. The basic system has been functioning highly reliably for a considerable time in many cities for the online

purchase of local public transport tickets. The TAN generator was developed as part of the „SaxMobility II“ project, in conjunction with the issue of utilisation rights for charging infrastructure systems.

In order to allow a better understanding of the functions described here, the fold-out page at the back of the catalogue provides corresponding explanations. Detailed product descriptions about charging stations, E-BoxX units, charging cables, etc. can be found in the corresponding chapters over the following pages.

Optional products and configuration possibilities

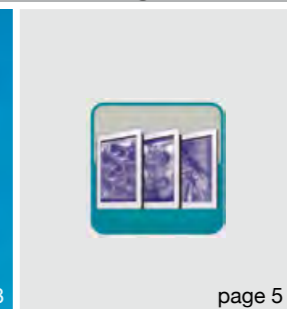

Operator (business model): Access-free charging system in multi-storey car parks

Operator (business model):
Access-free charging system
in multi-storey car parks

Situation:

More and more often, separate areas are being created in multi-storey car parks, ground-level car parks or underground car parks, for charging electric vehicles in which each parking space has a charging connection. Preferably, these are type 2 charging sockets or charging connections, since these allow all currently available vehicles to be charged directly or using their own charging cables. Customers in this area are drawn either from a particular user group or pay a charging supplement on top of the „normal“ parking charges. This means complicated identifications are unnecessary, as is an expensive, separate billing system. Irrespective of this, the system does face two additional challenges: The existing power supply is not sufficient when all charging points are occupied and charging, and frequently it is necessary to process information from the building management system (fire, peak load times, etc.).

Solution:

A central distributor – which can be a Walther charging station just as much as an ISO distributor or a switch-gear cabinet – supplies and controls several charging points, which generally speaking comprise E-BoxX units from the Slim-Line series. The Walther charge controllers contained in the charging points have the ability to limit the maximum charging

current of the corresponding charging point by means of a specified bit pattern. A controller in the central distributor and an intelligent communication network ensure that the charging current is reduced as the number of users increases (smart mode), and also provide the opportunity for external influencing (central mode). As an upgrade, the E-BoxX can be equipped with a fixed charging cable. The downgrade alternative is a lower-cost E-BoxX from the Industry-Line, also with a fixed cable.

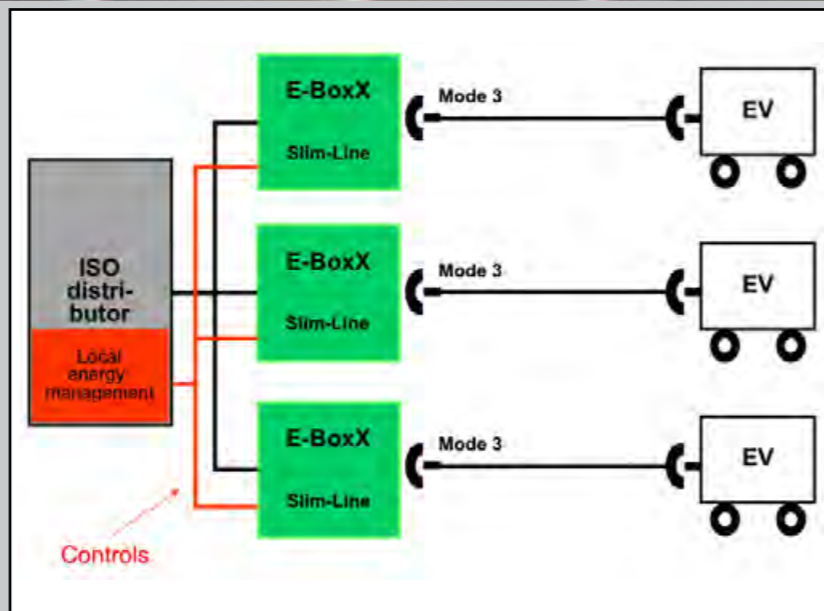

Description of function:

In this scenario, there is no activation of the charging points or any identification process, because the access restriction has already been imposed by the separation of the parking area. Following this, the customer plugs in his/her vehicle and the charging procedure starts immediately (type 1 plug) or after a switch is pressed (type 2 plugs and sockets). The charging process is terminated by disconnecting the plug (type 1 plug) or by switching off, thereby releasing the interlocking, after which the plug can be disconnected (type 2 plugs and sockets).



upgrade ↑



downgrade ↓

Product from scenario

Slim-Line

98200108, see page 80

Slim-Line

98200105, see page 81

Industry-Line

98100111, see page 74

Interesting features:

Suitable charging points include not only the suggested E-BoxX units in the Slim-Line, but also units from the Industry-Line and charging stations. The communication systems that can be used include network connections as well as the classic control cable connections which are currently recommended by Walther; many techniques can be used.

In order to allow a better understanding of the functions described here, the fold-out page at the back of the catalogue provides corresponding explanations. Detailed product descriptions about charging stations, E-BoxX units, charging cables, etc. can be found in the corresponding chapters over the following pages.

Optional products and configuration possibilities

page 5 page 5 page 76 page 78 page 64

Operator (business model): Connection of charging stations to existing parking ticket vending machines

Operator (business model):
Connection of charging stations to existing parking ticket vending machines

Situation:

Several spaces in a multi-storey car park are to be equipped with a charging connection. These are distributed throughout the facility, i.e. not within one enclosed area with separate cabinets. The existing communication and payment infrastructure will also be used, although must be expanded to take account of the charging function. There is a wide range of solutions available, and differ from one manufacturer of car park electronic systems to another. The existing parking ticket machine should handle activation of the charging sockets as well as billing and management of the electrical current drawn.

Solution:

One industrial sub-distribution board handles the interface function between the parking ticket machine and the charging points. The task of the sub-distribution board in this case is to pass on the authorisation signals from the parking ticket machine to the charging points. The charging points themselves can be housed in an E-BoxX from the Slim-Line product series. This has enough space for charge controllers, fuse elements and any meters. As a downgrade, the Slim-Line can be equipped with a charging socket rather than having a fixed cable. The upgrade involves charging stations from the ECOLECTRA product line with the same functions.

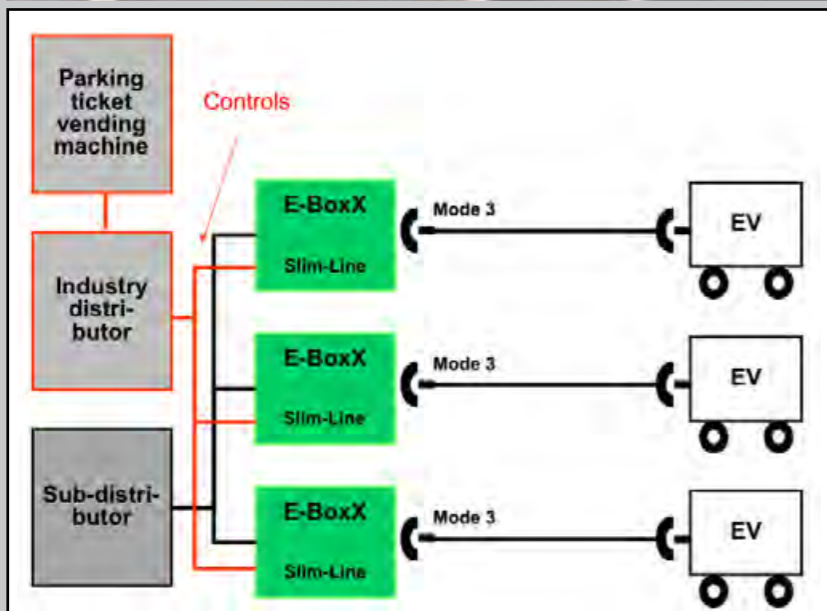

Description of function:

At the entrance barrier to the car park, the driver of the electric vehicle receives a car park token in the usual way. Next, the driver looks for a vacant space with a charging point. Once the vehicle has been connected to the charging point, the driver walks to the parking ticket machine and puts in the token. It is possible to select the additional „Park and Charge“ function on the machine's touchscreen. The new hourly rate for this is written onto the token. Now the driver can enter the parking space number. The parking ticket machine sends a signal to the industrial sub-distribution board which, in turn, activates the charging procedure at the selected parking space. When the driver returns, he or she pays for the parking at the parking ticket machine in the usual way.

Interesting features:

Usually, billing is not handled according to the amount of energy consumed, but the charging time (= parking time of the vehicle). This permits inexpensive solutions with acceptable investment costs. Usually, Slim-Line E-BoxX units from Walther are

used as a result of the extremely flat design and high mechanical stability they offer, in which case these units can have single or double equipment; alternatively different E-BoxX units and charging stations are suitable for use, e.g. ECOLECTRA 320 plus.

In order to allow a better understanding of the functions described here, the fold-out page at the back of the catalogue provides corresponding explanations. Detailed product descriptions about charging stations, E-BoxX units, charging cables, etc. can be found in the corresponding chapters over the following pages.

↑ upgrade

→

↓ downgrade

Product from scenario

	ECOLECTRA   M 15J0 10E00 60 see page 64
	Slim-Line   98200108 , see page 80
	Slim-Line   98200105 , see page 81

Optional products and configuration possibilities

		
page 5	page 5	page 98
		
page 76	page 78	

Operator (business model): Coin payment system with receipt delivery

Operator (business model):
Coin payment system
with receipt delivery

Situation:

A simple and low-cost solution for operators of charging stations with a business model in the background can take the form of a charging station with coin payment system. This means charging current can be purchased by the operator without requiring a complicated and cost-intensive charging infrastructure. In addition, user friendliness is the main feature, because there is no prior user registration required. This form of payment represents a good option for the comprehensive spread of electric mobility, because there are no access restrictions, and thus anyone can charge his/her vehicle without difficulty. The scenario is relevant for hotels, municipal authorities and car park operators, for example.



Solution:

Walther recommends using a charging station from the VOLTANEA product line to implement this approach. The coin payment system and the receipt printer are positioned on the front of the charging station. Up to 4 charging points (2x charging type 2, 2x Schuko socket) can be managed jointly using one charging station. As an upgrade, the VOLTANEA can additionally be equipped with a touchscreen. This makes it possible to request and implement charging parameters (charging current, charging time, etc.). In addition, the

touchscreen offers the possibility of showing products, tariffs or other customer information in the form of presentations or small films. As a downgrade, it is possible to use an ECOLECTRA with comparable functions.

Description of function:

The charging socket on the station is selected using buttons. Then, like in the case of a parking ticket vending machine, it is possible to purchase charging times by inserting coins, and for the times to be confirmed on a small text display. Internally, the charging is controlled by a timer. Furthermore, the charging station can be equipped with a receipt printer. This is particularly relevant for businesspeople who wish to reclaim their travel costs. The printer is connected to the controller by means of a corresponding interface. This means an invoice can be created and printed out for the charging fee paid. At the same time, the operator can store a defined set of information (date, time, charging fee, etc.) as print fields.

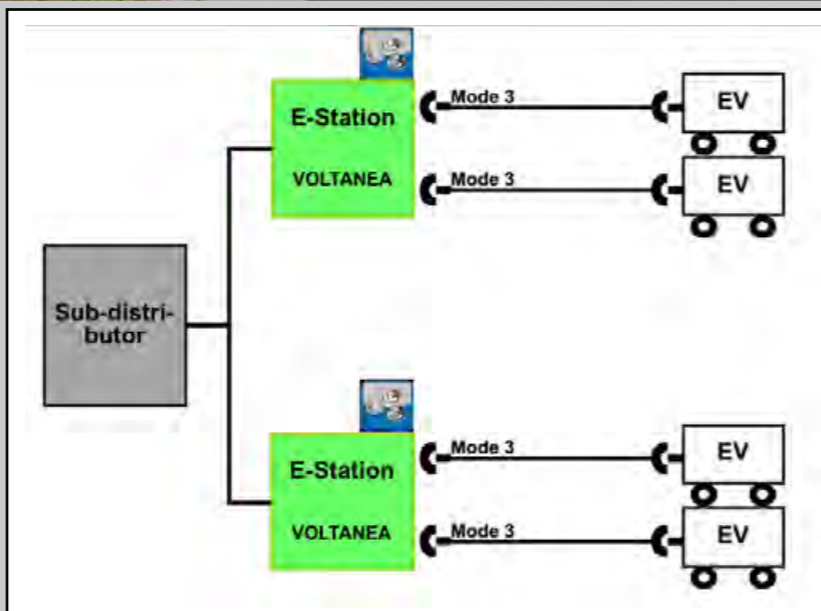

Interesting features:

If there is a relatively large number of charging points, cost savings can be achieved using a satellite system with E-BoxX units as the charging point, and a VOLTANEA 600 charging station as the central distributor. In that case, an energy management system and/or connection or integration into the building management system may be considered. The latter option makes sense if charging should be terminated and interlocked systems opened in the event of danger.

In order to allow a better understanding of the functions described here, the fold-out page at the back of the catalogue provides corresponding explanations. Detailed product descriptions about charging stations, E-BoxX units, charging cables, etc. can be found in the corresponding chapters over the following pages.



↑ upgrade

→

↓ downgrade

Product from scenario



VOLTANEA
Type 2 Schuko 22 kW
on request, see page 66



VOLTANEA
Type 2 Schuko 22 kW
on request, see page 66



ECOLECTRA
Type 2 Schuko 22 kW
on request, see page 64

Optional products and configuration possibilities



page 5



page 5



page 5

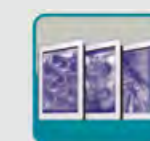

page 5

Operator (business model): Car sharing with online availability requests (charging station and vehicle)

Operator (business model):
Car sharing with online availability
requests (charging station and vehicle)

Situation:

The topic of car sharing is becoming increasingly important due to the growth of cities. Frequently, car sharing models are used by business travellers and private individuals for short journeys. Due to the issue of range, this offers promising prospects for the use of electric vehicles. Today, users principally book their vehicles using web applications. As a result, integrating an availability request for vehicles and vacant charging points is a logical next step. The users are already known to the operator via the registration process, and thus meet the conditions for a settlement process of rental costs and electricity consumption.

Solution:

The scenario can be implemented not only stand-alone but also with a satellite system. The availability requests described here (charging point vacant or which vehicle is at which charging station) require a GSM module for transmitting data from the charging station to the system of the car sharing operator. Walther recommends using a charging station from the VOLTANEA product line for this. E-BoxX units in the Robust-Line product line are suitable for use as satellites, because they offer a high level of vandal protection above all else. The fixed charging cable can be stored away behind the door of the E-BoxX. As the downgrade alternative, it is possible to use a Robust-Line without a fixed cable, i.e. only with a charging socket. As an upgrade, the satellites can also be ECOLECTRA charging stations.



Product from scenario

	ECOLECTRA  M 11J0 10E00 60 see page 65
	Robust-Line  98300103 , see page 78
	Robust-Line  98300108 , see page 78

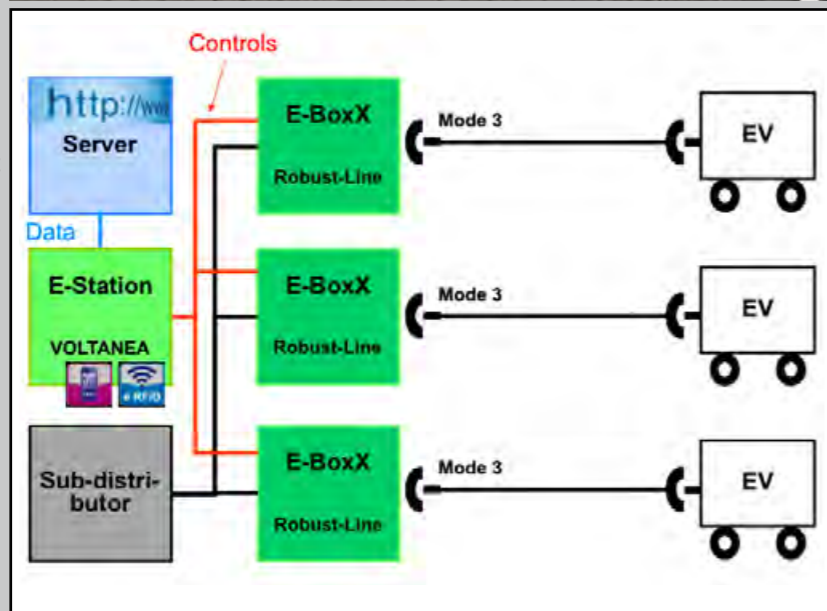





a vacant parking space. Having arrived, he/she identifies himself/herself at the charging station and selects a charging point. The E-BoxX is activated, the driver can connect the vehicle and charging starts. The new condition is transferred to the operator's server via GSM.

Interesting features:

According to requirements, it is also possible for utilisation and settlement data to be transferred directly to the driver's mobile phone. Alternatively, an e-mail can be sent to the driver. There is a wide range of technical configuration options here.

In order to allow a better understanding of the functions described here, the fold-out page at the back of the catalogue provides corresponding explanations. Detailed product descriptions about charging stations, E-BoxX units, charging cables, etc. can be found in the corresponding chapters over the following pages.

Optional products and configuration possibilities

		
page 5	page 5	page 5
		
page 80	page 68	

Installers: Test equipment for installation and maintenance activities ("e-check")

Installers:
Test equipment for installation and maintenance activities ("e-check")

Situation:

Electric mobility offers a very interesting and lucrative opportunity for electricians. Current market forecasts assume significant market growth during 2013, since the number of electric cars available then will increase sharply. Each of these cars requires at least one charging point, indeed some studies assume that 2.5 charging points will be required per vehicle. Installing many of these charging points will fall directly within the sphere of expertise of the electrical trade, in particular in the case of private customers and on company car parks. In addition to installing these charging facilities, a maintenance and servicing market („e-check“) will develop for the trade. Carrying out these activities proficiently will take know-how and the necessary equipment. Refer to the back of the catalogue for the training that Walther offers, meanwhile the correct test equipment is shown here.

out directly and used for assessing the result. One alternative represents a hand-held device (downgrade) which only checks the condition of the basic functions.

Solution:

Walther is regarded as the inventor of EV-Testers/Simulators. There are various configurations and designs for these. EV-Tester for type 1 plugs, EV-Tester for type 2 plugs and sockets and a combination device (upgrade) that allows the user to test both type 1 and type 2. The latter option thus offers the greatest flexibility. The integrated measuring instruments allow all relevant values to be read

out directly and used for assessing the result. One alternative represents a hand-held device (downgrade) which only checks the condition of the basic functions.

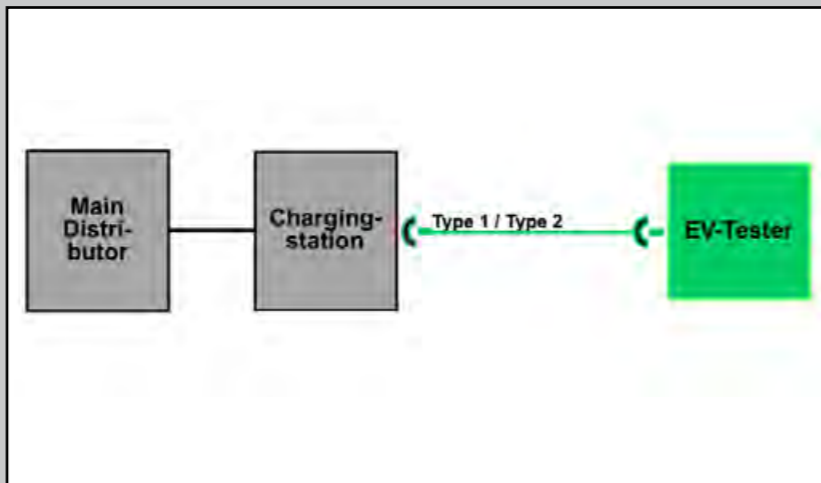

Description of function:

After charging stations and wallboxes have been installed, or when they have to be serviced, it is possible to check they are functioning correctly by simulating an electric vehicle. This also concerns existing charging cables. First, the EV tester/simulator is connected to the charging point (plugging into the charging socket or the fixed charging cable). Built-in toggle switches are used for simulating the coding resistance of the charging cable (13, 16/20, 32 or 63 A in type 2) as well as specifying the vehicle status B, C or D. The charging device responds accordingly, interlocks the plug and switches on the charging voltage (LED displays for switching status). The range of functions is supplemented by a test of the PE connection, BNC output for CP measurement as well as a switchable residual current for targeted FI tripping and load switching.

Interesting features:

Even without an electric vehicle available, it is possible to use the EV tester/simulator to check that all charging devices are functioning correctly, and to repair them rapidly during a service. This means the electrician can work efficiently and display expertise in the new business area.

In order to allow a better understanding of the functions described here, the fold-out page at the back of the catalogue provides corresponding explanations. Detailed product descriptions about charging stations, E-BoxX units, charging cables, etc. can be found in the corresponding chapters over the following pages.



upgrade ↑

→

downgrade ↓

Product from scenario

	EV-Tester / Simulator Type 1 Type 2 ABS IP 44 780121024, see page 99
	EV-Tester / Simulator Type 2 ABS IP 44 780001503, see page 98
	EV-Tester / Simulator Type 2 ABS IP 44 780001501, see page 98

Optional products and configuration possibilities

page 92	page 92	page 82
page 92	page 93	Training, see page 102

Charging station product range

Charging stations for an extremely wide range of applications as far as satellite systems

Market experience clearly shows that there is no ONE charging station which can cope with the wide variety of different aesthetic, functional and ergonomic requirements. Therefore, it is important to offer a high degree of flexibility in configuration in order to meet the various requirements. Walther offers an assortment of charging stations comprising three product lines for this purpose, by means of which you can implement the majority of current and future requirements already today. Above all, however, you remain flexible for possible changes.

For this reason, Walther has designed charging stations with exchangeable communication interfaces and racks which permit subsequent changes – such as installation of other communication systems or sockets – in all cases. This means you can enter the market at an early stage, whilst keeping control over your investments. All Walther charging stations feature a robust stainless steel enclosure (durability, vandal protection). Powder coating, paintwork without heavy metals, anti-graffiti coating (optional) are configured in accordance with customer's wishes. On the inside, a plastic distribution system of industrial quality offers a high IP rating for all electrical and electronic assemblies.



Your contact in all questions relating to E-Stations

Günther Wilhelmi
Tel.: +49 35 83 77 24-145
guenther.wilhelmi@walther-werke.de

ECOLECTRA



VOLTANEA



AMPEREA



Satellite system



ECOLECTRA

...the elegant station with a compact internal structure appeals with an astonishing number of possible variants. With ECOLECTRA, available in various sizes, it is possible to implement not only stand-alone versions but also very complex systems such as satellite systems by combining different sizes.

Expansion possibility



VOLTANEA

- The station with the asymmetrical outline can be arranged with several stations next to one another, in a star-shaped configuration or on a wall as required, without sacrificing any of its aesthetic appeal, functions or accessibility. However, even on its own the VOLTANEA looks good, just as when used as a communication centre in a satellite system.

Expansion possibility

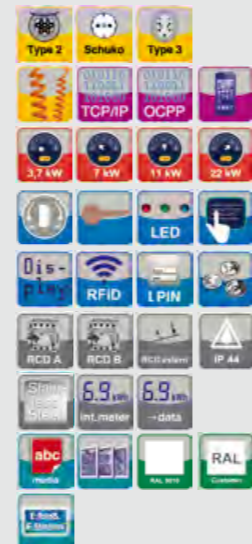

AMPEREA

- is the product line with the greatest volume. This offers space for a complete connection acc. to the special requirements of the power supplier (also with room for a "large" meter, the 300 mm manoeuvring space under the domestic junction box) and / or several of the customer's own communication systems.

Expansion possibility

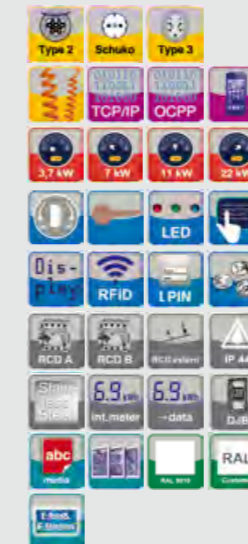

Expansion possibility



"All Walther E-BoxX units can be used with the ECOLECTRA, VOLTANEA and AMPEREA charging stations for satellite systems. In each case, depending on the installation location and configuration requirements."



ECOLECTRA 320 plus



ECOLECTRA 320 plus – the virtuoso

The ECOLECTRA 320 plus is the successor of the successful ECOLECTRA 320 and offers not only more space but also improved climate protection for your electrical and electronic components. This means it takes account of current developments and trends as well as the development of E-Mobility standards – in particular DIN EN 61439-7 (Low-voltage switchgear and control gear assemblies for ... charging stations for electric vehicles).

The ECOLECTRA 320 plus is used for connecting to an existing utility connection, and generally offers space for two charging points arranged on the sides.

As is usual with WALTHER, they have a modular structure and offer a range of different possibilities for equipping with different sockets, controllers, identification and communication methods. The equipment variants described below are ideal for the stations to be used in an extremely wide range of applications – from the simplest and most cost-effective basic design for installation in the works yard, for example, through to a solution with highly complex communication, identification and storage systems. Since introduction of the ECOLECTRA 320 plus series, certain standard configurations have largely developed with the following equipment types: “2 x charging with type 2 charging socket “ or “1 x charging with type 2 charging socket and 1 x charging with Schuko socket”. These are used successfully in almost all applications. These solutions can also be found in the six articles below.

If you do not find the configuration you are looking for, we will be happy to advise you.



Art. no.	Enclosure W x H x D (mm)	Charging point	Charging power	Identification and operation	Technical data	Data communication	Added-value services and CI design
M 15J0 10E00 60	320 x 320 x 1400	Type 2, Schuko	3,7 kW, 22 kW	LED	RCD B, IP 44, Stop button		abc, Media
M 15L1 12110 60	320 x 320 x 1400	Type 2, Schuko	3,7 kW, 22 kW	LED, RFID	RCD B, IP 44, Stop button, 6.9 kWh meter		abc, Media
M 1521 13530 60	320 x 320 x 1400	Type 2, Schuko	3,7 kW, 22 kW	RFID, LPIN	RCD B, IP 44, Stop button, 6.9 kWh meter	TCP/IP	abc, Media

Art. no.	Enclosure W x H x D (mm)	Charging point	Charging power	Identification and operation	Technical data	Data communication	Added-value services and CI design
M 11J0 10E00 60	320 x 320 x 1400	Type 2, Type 2	22 kW, 22 kW	LED	RCD B, IP 44, Stop button		abc, Media
M 11L1 12110 60	320 x 320 x 1400	Type 2, Type 2	22 kW, 22 kW	LED, RFID	RCD B, IP 44, Stop button, 6.9 kWh meter		abc, Media
M 1121 13520 60	320 x 320 x 1400	Type 2, Type 2	22 kW, 22 kW	RFID, LPIN	RCD B, IP 44, Stop button, 6.9 kWh meter	TCP/IP	abc, Media

Base matching ECOLECTRA 320 plus charging station, art. no. 821 325 95

The listed articles represent a current selection from the product line. In addition to this, there are many other variants of charging point – charging power – operation – technology and CI. Contact our specialists.

VOLTANEA 600



VOLTANEA 600 – a winner with design and function

The elegant Walther charging stations in the VOLTANEA 600 series are especially suitable for pavements in front of representative buildings or in car parks. In particular the new version, VOLTANEA 601, takes account of current developments and trends as well as the development of E-Mobility standards – in particular DIN EN 61439-7 (Low-voltage switchgear and control gear assemblies for ... charging stations for electric vehicles).

It has a modular structure, as is usual for Walther, and offers a range of different equipment possibilities. As a result of this, all identification, communication and billing systems can be implemented. The integrated controller is responsible for the entire charging procedure, the dialogue with customers and operators as well as the safety-relevant functions in case of a fault or danger. The same applies for the optional storage of consumption data records and the further processing of them. Frequently, a special SD card in the controller makes it straightforward to change the program and parameters subsequently.

The VOLTANEA 600 is prepared for connection to an existing utility connection, and generally offers space for 4 charging points on the front, usually configured for "2 x charging with type 2 charging socket and 2 x charging with Schuko socket". These solutions can also be found in the six articles below.

Refer to the equipment examples for more details. If you do not find the configuration you want, please contact us for advice.



Art. no.	Enclosure W x H x D (mm)	Charging point	Charging power	Identification and operation	Technical data	Data communication	Added-value services and CI design
M 68K0 10E00 60	603 x 323 x 1603	Type 2, Schuko	22 kW, 22 kW	LED	RCO B, IP 44		abc, media
M 68M1 12110 60	603 x 323 x 1603	Type 2, Schuko	22 kW, 22 kW	LED, RFID	RCO B, IP 44, 6.9 kWh		abc, media
M 6821 13520 60	603 x 323 x 1603	Type 2, Schuko	22 kW, 22 kW	RFID, LPIN	RCO B, IP 44, 6.9 kWh	TCP/IP	abc, media

Art. no.	Enclosure W x H x D (mm)	Charging point	Charging power	Identification and operation	Technical data	Data communication	Added-value services and CI design
M 6811 13B20 60	603 x 323 x 1603	Type 2, Schuko	22 kW, 22 kW	LTAN	RCO B, IP 44, 6.9 kWh	TCP/IP	abc, media
M 6821 13C20 60	603 x 323 x 1603	Type 2, Schuko	22 kW, 22 kW	RFID	RCO B, IP 44, 6.9 kWh	OCPP	abc, media
M 6811 13D20 60	603 x 323 x 1603	Type 2, Schuko	22 kW, 22 kW	eTAN	RCO B, IP 44, 6.9 kWh		abc, media

Base matching VOLTANEA 600 charging station art. no. 821 600 95

The listed articles represent a current selection from the product line. In addition to this, there are many other variants of charging point – charging power – operation – technology and CI. Contact our specialists.

AMPEREA 800



AMPEREA 800 – maximum connection space for your special requirements

The Walther AMPEREA 800 charging station has a modular structure and, due to the size of the enclosure, offers advantages especially where a public connection must be established acc. to the special requirements of the energy supplier. This means the AMPEREA 800 offers space for a domestic junction box NH00, an SLS 80 A, a meter housing (large and wired up ready for connection) as well as installation space for the customer's tariff control unit. These requirements usually apply in the public sector. The station meets the requirements of all current developments and trends, as well as the development of E-Mobility standards – especially DIN EN 61439-7 (Low-voltage switchgear and control gear assemblies ... for charging stations for electric vehicles).

AMPEREA 800 generally offers space for up to 4 charging points, usually configured for "2 x charging with type 2 charging socket and 2 x charging with Schuko socket". You can also find these solutions in the five articles below. The integrated controller is responsible for the entire charging procedure, the dialogue with customers and operators as well as the safety-relevant functions in case of a fault or danger. The same applies for the optional storage of consumption data records and the further processing of them. Frequently, a special SD card in the controller makes it straightforward to change the program and parameters subsequently.

Refer to the equipment examples for more details. If you do not find the configuration you want, please contact us for advice.



Art. no.	Enclosure W x H x D (mm)	Charging point	Charging power	Identification and operation	Technical data	Data communication	Added-value services and CI design
M 28M1 22110 60	928 x 337 x 1593	Type 2, Type 2, Schuko, Schuko	22 kW, 22 kW	RFID, LED, Dis	RCO B, IP-44, QJB, 6.9, int. meter		abc, walther
M 2821 23520 60	928 x 337 x 1593	Type 2, Type 2, Schuko, Schuko	22 kW, 22 kW	RFID, LPIN	RCO B, IP-44, QJB, 6.9, -data	TCP/IP	abc, walther
M 2811 23B20 60	928 x 337 x 1593	Type 2, Type 2, Schuko, Schuko	22 kW, 22 kW	LTAN	RCO B, IP-44, QJB, 6.9, -data	TCP/IP	abc, walther

Art. no.	Enclosure W x H x D (mm)	Charging point	Charging power	Identification and operation	Technical data	Data communication	Added-value services and CI design
M 2821 23C20 60	928 x 337 x 1593	Type 2, Type 2, Schuko, Schuko	22 kW, 22 kW	e RFID	RCO B, IP-44, QJB, 6.9, -data	OCPP	abc, walther
M 2811 23D20 60	928 x 337 x 1593	Type 2, Type 2, Schuko, Schuko	22 kW, 22 kW	eTAN	RCO B, IP-44, QJB, 6.9, -data		abc, walther

Base matching AMPEREA 800 charging station art. no. 821 800 95

The listed articles represent a current selection from the product line. In addition to this, there are many other variants of charging point – charging power – operation – technology and CI. Contact our specialists.

Walther charging stations offer user identification and communication by various processes



A user identification is the basic requirement for consumption billing, charging prioritisation, access limitation or authorisation of the charging socket. Here too, Walther offers a full range of technical solutions for performing this identification.

Key-operated switch

The simplest form of ensuring that only authorised people have access for charging is certainly – specifically in the private or semi-public sphere – to use mechanical keys in the form of key-operated or knob switches. This version is especially suitable for stand-alone versions.

PIN

Another simple form of identification is by using a PIN. The user identifies himself/herself using a number keypad or a touchscreen and the known PIN, thus receiving access to the charging socket. This version is especially suitable for stand-alone versions.

RFID

Identification using an RFID transponder (radio frequency identification) is controlled by a reader on the charging station. It is possible to store a selection of user information on the RFID transponder prior to use, and this can be transferred to the charging station during identification as a means of documentation. The RFID transponder can be fitted in various ways, for example as a chip card, on the vehicle, in the charging plug, etc. This allows identification to be controlled without extra work by the user. This version is suitable both for stand-alone versions (localRFID for small user groups) as well as for a version linked to a backend (extendedRFID). Comparison with the white lists and black lists stored at the backend can take place both using special protocols (such as OCPP) and special connections with additional protection (VPN channel) or networks.

TAN

Various possibilities derive from the use of transaction numbers (TANs). In the localTAN/SMS process, the charging station generates a TAN. The user identifies himself/herself by sending an SMS with this TAN and his/her sender ID to a charging station from a mobile phone. The user can charge providing this data matches the stored data.

In the extendedTAN system, the customer selects the socket and charging time or tariff at the station and, as a result of this dialogue, receives an administration number from a "TAN generator", which is created by a complicated mathematical algorithm. He/she sends this number to a provider as an SMS and, once the message has been checked, receives an SMS back containing a TAN. Once this has been entered via the touchscreen, the corresponding socket is released for the required time. At the same time, the customer's mobile phone account is debited by the corresponding amount. All of these communication processes will be significantly simplified in future through the use of smartphones, QR codes and special apps.



Consumption measurement and billing by "smart" charging stations



Our many years of experience shows that there are different system solutions and versions for charging stations with integrated energy measurement and billing in energy distribution systems and energy billing systems (large leisure systems, yachting marinas, etc.). Walther frequently handles the billing procedure using the following system: The energy drawn from the power system is measured by electronic meters in kWh (single-phase or three-phase smart meters), this measurement is then stored and prepared for data transfer. A complete data record is created and stored for each charging procedure, containing at least the customer identification (from RFID, PIN, mobile phone sender), time stamp and consumption. If required, this data record can also contain a series of additional data derived from a start dialogue. For example, this could include selected tariffs or specifications by the utility about maximum charging current during the charging process.

Alternatively, Walther integrates EDMs (electronic domestic meters) from the responsible utility. Many Walther charging stations offer provision for extensive adaptations to the users' requirements, which can be undertaken using a connected laptop with Ethernet interface and web browser. Sending an SMS to the maintenance service in case of a fault, the appropriate telephone numbers, operating statuses, input of PIN and TAN – many administrator functions can be implemented with ease using an attractive software and user interface.

Tried-and-tested payment methods

Coins or tokens

The charging power is paid for using coins (1 €, 2 €) or tokens. Usually, the energy drawn from the power system is measured using built-in meters, although it is also possible to activate the charging socket for the paid time period – irrespective of the amount of energy. This solution is particularly popular in combination with another billing system.

Central billing systems

The energy drawn from the power system is measured by built-in meters in this case, and this information is stored together with a user identity and the necessary time values in a data record for each individual charging procedure. These data records are transferred immediately or periodically to the central station. The transmission media used in implemented systems include both hard-wired systems (data cables, bus systems such as EIB/KNX, etc.) and wireless data transfers with secure protocols such as OCPP. This involves carrying out a large number of functions and even software updates centrally. This solution is particularly suitable for larger, decentralised applications in public and non-public areas, as well as in distributed complexes. Various processes are available in this case, with both a permanent connection to the backend (online solutions) and intelligent offline solutions in which the user takes over communication with the backend and ultimately pays for this (extendedTAN process, etc.).

For special applications, it is also possible to combine the various billing systems or to integrate the customer's own subsystems into the charging stations for reasons of data supremacy.

Decentralised billing systems

The data records described in the section on central billing systems can also be stored over a defined period of time and read out at intervals in the form of an Excel sheet via a connected laptop. This function is particularly suitable for operators which are only expecting a low user frequency, or which only really require the user data for statistical purposes.



E-BoxX product range

"All Walther E-BoxX units can be used with the ECOLECTRA, VOLTANEA and AMPEREA charging stations for satellite systems. In each case, depending on the installation location and configuration requirements."

E-BoxX or wallbox is the name of those power supply units for electric vehicles, which are wall mounted. They are used as domestic charging stations in private garages, carports, public multi-storey car parks, underground garages, reserved charging areas for vehicle fleets, etc.

Walther uses plastic, stainless steel or aluminium as enclosure material depending on the particular requirements with regard to temperature, humidity, stability, etc. The E-BoxX is selected according to the existing or future electric vehicle, and installed by the specialist electrical company. Only the electrical supply cable is required. Basically, the wallboxes are divided into the categories of single-phase and three-phase charging in the power range from 3 kW to 22 kW.

The safety devices used are RCDs (residual current devices), miniature circuit breakers (MCBs) as well as charging sockets. The safety devices can be already installed in the upstream installation in some variants rather than in the E-BoxX

itself, or else be newly installed there. In mode 3, additional safety functions are defined (detection of cable cross section) and communication (specification of the maximum charging current to the electric vehicle as PWM signal).

Walther produces the E-BoxX in versions with a type 2 charging socket or, alternatively, with a fixed cable including the appropriate vehicle connector (type 1 or type 2) to the electric vehicle. On request, it is also possible to provide a Schuko socket for charging according to mode 2, or for charging pedelecs. An integrated meter (optional) makes it possible to read off the "driven" electricity.

The power distribution can be influenced for all supply parameters that do not permit a simultaneity factor of 1, by means of local energy management and internal or external specifications. As a result, controlled charging can be implemented.



Your contact in all questions relating to E-BoxX

Nikola Milosavljevic
Tel.: +49 63 51 4 75-288
nikola.milosavljevic@walther-werke.de

Industry-Line



Industry-Line

Product line from the tried-and-tested enclosure system in a spacious plastic enclosure. Two enclosure sizes for power levels from 3.7 kW to 22 kW.

Expansion possibility



Design-Line



Design-Line

Design-oriented for charging at home, in the compact plastic enclosure. Charging current 16 A, preferably fixed charging cable.

Expansion possibility



Robust-Line



Robust-Line

Stainless steel enclosure, painted, for use in harsh environments. Lockable door prevents misuse.

Expansion possibility

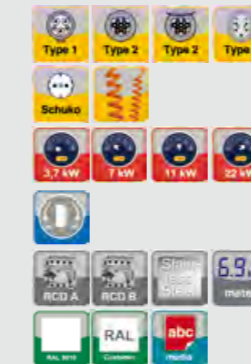

Slim-Line



Slim-Line

Extremely robust enclosure with reduced construction height, made from aluminium. Charging socket or fixed charging cable.

Expansion possibility



Industry-Line



Industry-Line

The Industry-Line product line is based on the enclosure system of Walther socket combinations for decentralised energy distribution that has proven its effectiveness over many years. The spacious plastic enclosure provides enough space for the necessary safety devices such as RCD (residual current device), miniature circuit breaker (MCB) as well as the charge controller for communication with the electric vehicle. These devices for DIN-rail mounting can be accessed from the outside, behind a flap, depending on the enclosure design.

The safety devices can also be integrated into the upstream installation as an alternative. This is done by specialist electrical companies in compliance with the manufacturer's specifications and relevant installation regulations.

The Industry-Line enables you to provide single-phase and/or three-phase charging in the power range from 3 kW to 22 kW, depending on configuration. Optionally, it is also possible to provide a Schuko socket for charging according to mode 2, or for charging pedelecs.

Depending on the version, either a type 2 charging socket or a fixed cable (straight or spiral) with the appropriate vehicle connector (type 1 or type 2) for the electric vehicle is provided, with the cable cross section according to the available max. charging power. In the E-BoxX with type 2 charging socket, the electric vehicle is connected using an additional mode 3 charging cable.

Knob switches, key-operated switches and LEDs for signalling are installed, depending on the variant, for operation and/or activation of the charging procedure. Optionally, the E-BoxX units have an integrated meter for reading off the "driven" electricity. Additional mechanical protection is available for the Industry-Line as an option, comprising roofs and side protection. All variants from the Walther range of free standing pillars can be used here.

Application/location of use: Carports, underground garages, multi-storey car parks, optionally in conjunction with local energy management.

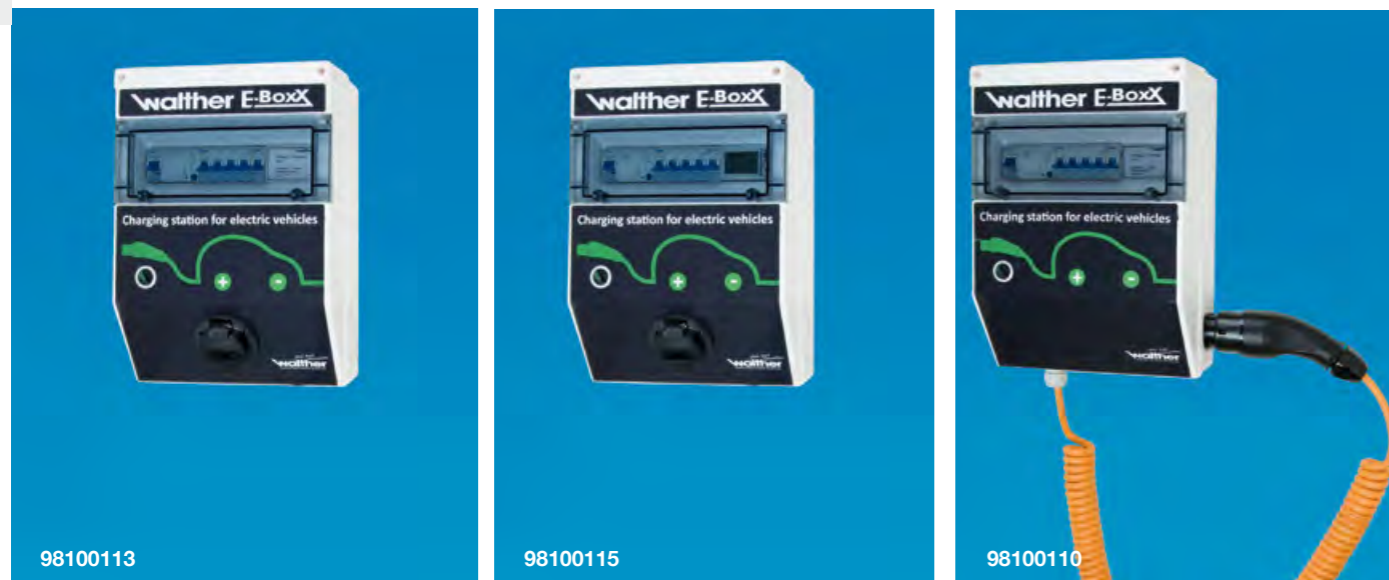

Art. no.	Enclosure W x H x D (mm)	Residual current devices and circuit breakers	Charging point and charging power	Identification and operation	Technology	Data communication	Added-value services and CI design
98100108	183 x 370 x 152 Connection terminals 2 x 5 x 25 mm ²	RCBO 16 A 2-pole type A	Type 1 3.7 kW	LED	RCD A, IP 44, ABS		abc
98100109	183 x 370 x 152 Connection terminals 2 x 5 x 25 mm ²	RCBO 16 A 2-pole type A extern	Type 1 3.7 kW	LED	RCD extern, IP 44, ABS		abc
98100110	290 x 404 x 171 Connection terminals 2 x 5 x 25 mm ²	RCD 40 A 4-pole type B AC/DC sensitive MCB 16 A 3-pole+N, C	Type 2 11 kW	LED	RCD B, IP 44, ABS		abc
98100111	183 x 370 x 152 Connection terminals 2 x 5 x 25 mm ²	RCD 40 A 4-pole type B AC/DC sensitive extern MCB 16 A 3-pole+N, C	Type 2 11 kW	LED	RCD extern, IP 44, ABS		abc

Art. no.	Enclosure W x H x D (mm)	Residual current devices and circuit breakers	Charging point and charging power	Identification and operation	Technology	Data communication	Added-value services and CI design
98100112	290 x 404 x 171 Connection terminals 2 x 5 x 25 mm ²	RCD 40 A 4-pole type B AC/DC sensitive MCB 16 A 3-pole+N, C	Type 2 11 kW	LED	RCD B, IP 44, ABS		abc
98100113	290 x 404 x 171 Connection terminals 2 x 5 x 25 mm ²	RCD 40 A 4-pole type B AC/DC sensitive MCB 32 A 3-pole+N, C	Type 2 22 kW	LED	RCD B, IP 44, ABS		abc
98100114	290 x 404 x 171 Connection terminals 2 x 5 x 25 mm ²	RCD 40 A 4-pole type B AC/DC sensitive extern MCB 32 A 3-pole+N, C RCBO 16 A 2-pole type A	Type 2 22 kW	LED	RCD extern, IP 44, ABS		abc
98100115	290 x 404 x 171 Connection terminals 2 x 5 x 25 mm ²	RCD 40 A 4-pole type B AC/DC sensitive MCB 32 A 3-pole+N, C RCBO 16 A 2-pole type A	Type 2 22 kW	LED	RCD B, IP 44, ABS, meter		abc

The listed articles represent a current selection from the product line. In addition to this, there are many other variants of charging point – charging power – operation – technology and CI. Contact our specialists.

Design-Line



Design-Line

The Design-Line product line has been specially conceived for charging at home in the garage. Particular emphasis has been placed on a design-oriented and elegant enclosure. The compact plastic enclosure provides space for the necessary safety devices such as RCD (residual current device), miniature circuit breaker (MCB) as well as the charge controller for communication with the electric vehicle.

The safety devices can also be integrated into the upstream installation as an alternative. This is done by specialist electrical companies in compliance with the manufacturer's specifications and relevant installation regulations.

The Design-Line enables you to provide single-phase and/or three-phase charging in the power range from 3 kW to 11 kW for commonly used electric vehicles.

Depending on the variant, either a type 2 charging socket is integrated or a fixed cable with the appropriate vehicle connector (type 1 or type 2) to the electric vehicle. This charging cable can be configured both as a spiral cable and a straight cable with the cable cross section according to the available max. charging power. The vehicle connector is accommodated at the right side of the enclosure by hooking in when not in use. In the E-BoxX with type 2 charging socket, the electric vehicle is connected using an additional mode 3 charging cable.

Depending on the variant, knob switches, key-operated switches as well as LEDs for signalling are installed, for operation and/or activation of the charging procedure.

Application/location of use: Private garages, showrooms.

5

5

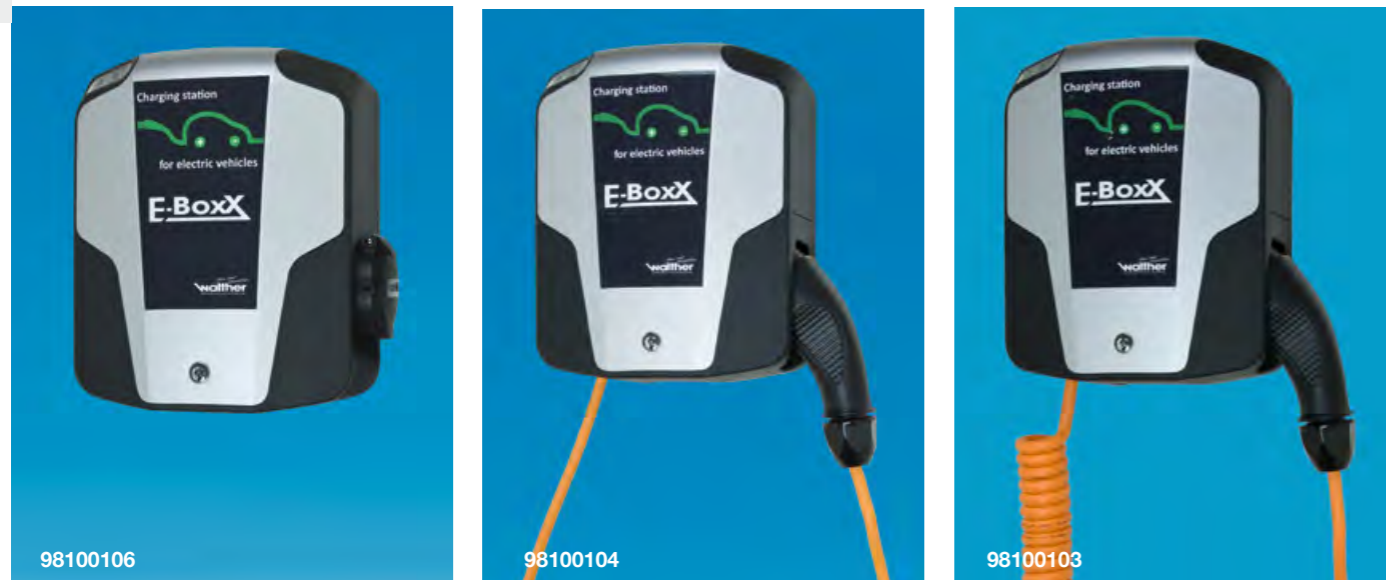

Art. no.	Enclosure W x H x D (mm)	Residual current devices and circuit breakers	Charging point and charging power	Identification and operation	Technology	Data communication	Added-value services and CI design
98100100	235 x 280 x 125 Connection terminals 3 x 4 mm ²	RCBO 16 A 2-pole-type A	Type 1 3.7 kW	LED	RCD A, IP-44, ABS		abc
98100101	235 x 280 x 125 Connection terminals 3 x 4 mm ²	RCBO 16 A 2-pole type A	Type 1 3.7 kW	LED	RCD A, IP-44, ABS		abc
98100102	235 x 280 x 125 Connection terminals 3 x 4 mm ²	RCBO 16 A 2-pole type A - extern	Type 1 3.7 kW	LED	RCD extern, IP-44, ABS		abc
98100103	235 x 280 x 125 Connection terminals 3 x 4 mm ²	RCBO 16 A 2-pole type A	Type 2 3.7 kW	LED	RCD A, IP-44, ABS		abc

Art. no.	Enclosure W x H x D (mm)	Residual current devices and circuit breakers	Charging point and charging power	Identification and operation	Technology	Data communication	Added-value services and CI design
98100104	235 x 280 x 125 Connection terminals 3 x 4 mm ²	RCBO 16 A 2-pole type A	Type 2 3.7 kW	LED	RCD A, IP-44, ABS		abc
98100105	235 x 280 x 125 Connection terminals 5 x 4 mm ²	RCD 40 A 4-pole type B AC/DC sensitive extern MCB 16 A 3-pole+N, C - extern	Type 3 11 kW	LED	RCD extern, IP-44, ABS		abc
98100106	235 x 280 x 125 Connection terminals 3 x 4 mm ²	RCBO 16 A 2-pole type A	Type 2 3.7 kW	LED	RCD A, IP-44, ABS		abc
98100107	235 x 280 x 125 Connection terminals 5 x 4 mm ²	RCD 40 A 4-pole type B AC/DC sensitive extern MCB 16 A 3-pole+N, C - extern	Type 2 11 kW	LED	RCD extern, IP-44, ABS		abc

The listed articles represent a current selection from the product line. In addition to this, there are many other variants of charging point – charging power – operation – technology and CI. Contact our specialists.

Robust-Line

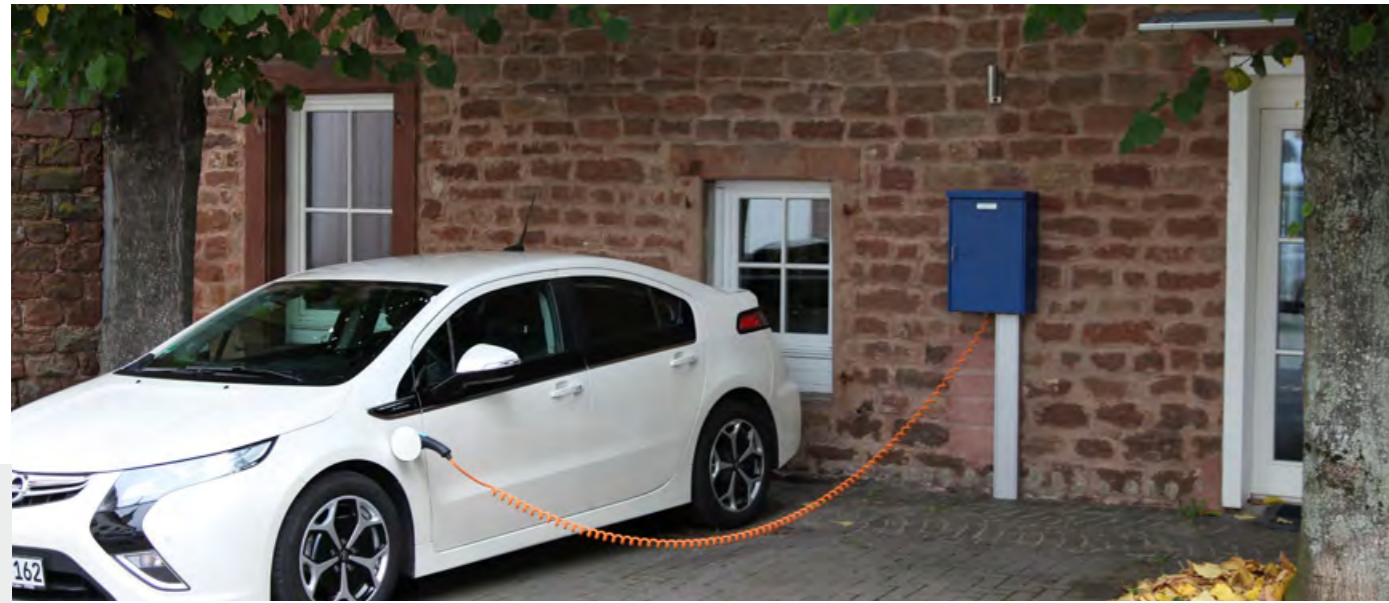

Robust-Line

The Robust-Line product line is based on the power distributor system that has proven its effectiveness over many years for decentralised energy distribution in the outside area. The spacious stainless steel enclosure is painted and offers optimum protection at the same time as good heat dissipation. It provides space for the necessary safety devices such as RCD (residual current device), miniature circuit breaker (MCB) as well as the charge controller for communication with the electric vehicle. These devices for DIN-rail mounting are mounted on DIN rails, and can be accessed from the outside by opening a lockable door.

The Robust-Line enables you to provide single-phase and/or three-phase charging in the power range from 3 kW to 22 kW, depending on configuration. Optionally, it is also possible to provide a Schuko socket for charging according to mode 2, or for charging pedelecs.

Depending on the variant, either a type 2 charging socket is integrated or a fixed cable with the appropriate vehicle connector (type 1 or type 2) to the electric vehicle. This charging cable can be configured both as a spiral cable and a straight cable with the cable cross section according to the available max. charging power. The vehicle connector is stored behind the door in the enclosure. In the E-BoxX with type 2 charging socket, the electric vehicle is connected using an additional mode 3 charging cable.

A knob switch with LED for signalling is installed for operation and/or activation of the charging procedure.

Application/location of use: Outside area on garages, carports.



Art. no.	Enclosure W x H x D (mm)	Residual current devices and circuit breakers	Charging point and charging power	Identification and operation	Technology	Data communication	Added-value services and CI design
98300100	435 x 653 x 250 Connection terminals 2 x 5 x 25 mm ²	RCBO 16 A 2-pole type A	Type 1 3.7 kW	LED	RCD A, IP-44, Schuko		RAL 9005, RAL 9006, abc
98300101	435 x 653 x 250 Connection terminals 2 x 5 x 25 mm ²	RCBO 16 A 2-pole type A	Type 1 3.7 kW	LED	RCD A, IP-44, Schuko		RAL 9005, RAL 9006, abc
98300102	435 x 653 x 250 Connection terminals 2 x 5 x 25 mm ²	RCD 16 A 4-pole type B AC/DC sensitive MCB 16 A 3-pole+N, C	Type 2 11 kW	LED	RCD B, IP-44, Schuko		RAL 9005, RAL 9006, abc
98300103	435 x 653 x 250 Connection terminals 2 x 5 x 25 mm ²	RCD 40 A 4-pole type B AC/DC sensitive MCB 16 A 3-pole+N, C	Type 2 11 kW	LED	RCD B, IP-44, Schuko		RAL 9005, RAL 9006, abc

Art. no.	Enclosure W x H x D (mm)	Residual current devices and circuit breakers	Charging point and charging power	Identification and operation	Technology	Data communication	Added-value services and CI design
98300104	435 x 653 x 250 Connection terminals 2 x 5 x 25 mm ²	RCD 40 A 4-pole type B AC/DC sensitive MCB 32 A 3-pole+N, C	Type 2 22 kW	LED	RCD B, IP-44, Schuko		RAL 9005, RAL 9006, abc
98300105	435 x 653 x 250 Connection terminals 2 x 5 x 25 mm ²	RCD 40 A 4-pole type B AC/DC sensitive MCB 32 A 3-pole+N, C	Type 2 22 kW	LED	RCD B, IP-44, Schuko	6.9 meter	RAL 9005, RAL 9006, abc
98300106	435 x 653 x 250 Connection terminals 2 x 5 x 25 mm ²	RCD 40 A 4-pole type B AC/DC sensitive MCB 16 A 3-pole+N, C RCBO 16 A 2-pole type A	Type 2 Schuko 11 kW, 3.7 kW	LED	RCD B, RCD A, IP-44		RAL 9005, RAL 9006, abc
98300107	435 x 653 x 250 Connection terminals 2 x 5 x 25 mm ²	RCD 40 A 4-pole type B AC/DC sensitive MCB 32 A 3-pole+N, C RCBO 16 A 2-pole type A	Type 2 Schuko 22 kW, 3.7 kW	LED	RCD B, RCD A, IP-44		RAL 9005, RAL 9006, abc

The listed articles represent a current selection from the product line. In addition to this, there are many other variants of charging point – charging power – operation – technology and CI. Contact our specialists.

Slim-Line



Slim-Line

In the Slim-Line product line, particular emphasis was placed on achieving an extremely robust enclosure with a low construction height of only 125 mm. The compact aluminium enclosure provides space for the required safety devices such as RCD (residual current device), miniature circuit breaker (MCB) as well as the charge controller for communication with the electric vehicle. These devices for DIN-rail mounting are mounted on DIN rails and, depending on the enclosure configuration, can be accessed from the outside by opening a flap.

The Slim-Line enables you to provide single-phase and/or three-phase charging in the power range from 3 kW to 22 kW, depending on configuration. Optionally, it is also possible to provide a Schuko socket for charging according to mode 2, or for charging pedelecs.

Depending on the variant, either a type 2 charging socket is integrated or a fixed cable with the appropriate vehicle connector (type 1 or type 2) to the electric vehicle. This charging cable can be configured both as a spiral cable and a straight cable with the cable cross section according to the available max. charging power. In the E-BoxX with type 2 charging socket, the electric vehicle is connected using an additional mode 3 charging cable.

Depending on the variant, knob switches, key-operated switches as well as LEDs for signalling are installed, for operation and/or release of the charging procedure.

Application/location of use: Underground garages, multi-storey car parks, outside area, optionally in conjunction with local energy management.

5

5



Art. no.	Enclosure W x H x D (mm)	Residual current devices and circuit breakers	Charging point and charging power	Identification and operation	Technology	Data communication	Added-value services and CI design
98200100	230 x 600 x 125 Connection terminals 3 x 6 mm ²	RCBO 16 A 2-pole type A	Type 1 3.7 kW	LED	RCD A, IP-44, AFD		RAL 9010, RAL 9005, abc, Media
98200101	230 x 600 x 125 Connection terminals 3 x 6 mm ²	RCBO 16 A 2-pole type A	Type 1 3.7 kW	LED	RCD A, IP-44, AFD		RAL 9010, RAL 9005, abc, Media
98200102	230 x 600 x 125 Connection terminals 2 x 3 x 6 mm ²	RCBO 16 A 2-pole type A RCBO 16 A 2-pole type A	Type 1, Type 1 3.7 kW, 3.7 kW	LED, LED	RCD A, RCD A, IP-44, AFD		RAL 9010, RAL 9005, abc, Media
98200103	230 x 600 x 125 Connection terminals 5 x 6 mm ²	RCD 40 A 4-pole type B AC/DC sensitive MCB 16 A 3-pole+N, C	Type 2 11 kW	LED	RCD B, IP-44, AFD		RAL 9010, RAL 9005, abc, Media

Art. no.	Enclosure W x H x D (mm)	Residual current devices and circuit breakers	Charging point and charging power	Identification and operation	Technology	Data communication	Added-value services and CI design
98200104	230 x 600 x 125 Connection terminals 5 x 6 mm ²	RCD 40 A 4-pole type B AC/DC sensitive MCB 16 A 3-pole+N, C	Type 2 11 kW	LED	RCD B, IP-44, AFD		RAL 9010, RAL 9005, abc, Media
98200105	230 x 600 x 140 Connection terminals 5 x 10 mm ²	RCD 40 A 4-pole type B AC/DC sensitive MCB 32 A 3-pole+N, C	Type 2 22 kW	LED	RCD B, IP-44, AFD		RAL 9010, RAL 9005, abc, Media
98200106	230 x 600 x 140 Connection terminals 5 x 10 mm ²	RCD 40 A 4-pole type B AC/DC sensitive MCB 32 A 3-pole+N, C	Type 2 22 kW	LED	RCD B, IP-44, AFD	6.9 meter	RAL 9010, RAL 9005, abc, Media
98200107	230 x 600 x 140 Connection terminals 5 x 6 mm ²	RCD 40 A 4-pole type B AC/DC sensitive MCB 16 A 3-pole+N, C RCBO 16 A 2-pole type A	Type 2, Schuko 11 kW, 3.7 kW	LED, LED	RCD B, RCD A, IP-44, AFD		RAL 9010, RAL 9005, abc, Media

The listed articles represent a current selection from the product line. In addition to this, there are many other variants of charging point – charging power – operation – technology and CI. Contact our specialists.

Special solutions
Trolley, suspension-type combination, solid rubber distributor



Trolley, suspension-type combination, solid rubber distributor

Innovative special solutions from the engineering team at Walther support car makers in the area of development and testing of new electric vehicles. Here, fast and flexible solutions are called for in order to provide a charging infrastructure under special environmental or general conditions. For example, this concerns charging the vehicles in locations where only CEE sockets are available for energy supply. Charging points for ceiling mounting are available for production and workshop areas without any suitable wall surfaces for installation.

E-BoxX in design as mobile supply unit

The mobile supply unit is a portable version of an Industry-Line E-BoxX, installed in a sturdy trolley case. Integrated supply cable equipped with CEE-connectors 16 A or 32 A, type 2 charging socket, 32 A, 3-phase and with a PWM rated value specification on up to 7 stages by the user. On the power system side, the PE is checked by an integrated protective earth monitoring module on connection using a test key, and monitored permanently during operation. Optionally, a meter can be installed in order to read off the „driven“ electricity.

E-BoxX in design as suspension-type box

The suspension-type combination based on the Industry-Line enclosure system is a particularly small and space-saving supply unit for ceiling mounting. Normally, it is suspended by chains or cables, and the energy supply comes from above. Optionally, it is possible to integrate a compressed air line with quick-release coupling as well as a PWM rated value specification via BCD switch. The electric vehicle is connected to the integrated type 2 charging socket using a charging cable.

E-BoxX in design as solid rubber distributor

Rubber distributors can be divided into the categories of portable versions or wall-mounted versions, depending on their design. They have proven effective over many years under the toughest conditions on construction sites, at events, in welding stations, etc. A compact solid rubber enclosure with a 10 mm wall thickness contains the necessary components for charging an electric vehicle. A type 2 charging socket is available as the charging point.



Art. no.	Enclosure W x H x D (mm)	Residual current devices and circuit breakers	Charging point and charging power	Identification and operation	Technology	Data communication	Added-value services and CI design
98400100	400 x 600 x 330	RCD 40 A 4-pole type A MCB 16 A 3-pole+N, C PE-monitoring	Type 2 11 kW	LED	RCD A		
98400101	400 x 600 x 330	RCD 40 A 4-pole type A MCB 32 A 3-pole+N, C PE-monitoring	Type 2 22 kW	LED	RCD A		
98400102	400 x 600 x 330	RCD 40 A 4-pole type A MCB 32 A 3-pole+N, C PE-monitoring	Type 2 22 kW	LED	RCD A		
98400103	400 x 600 x 330	RCD 40 A 4-pole type A MCB 32 A 3-pole+N, C PE-monitoring	Type 2 22 kW	LED	RCD A 6.9 meter		

Art. no.	Enclosure W x H x D (mm)	Residual current devices and circuit breakers	Charging point and charging power	Identification and operation	Technology	Data communication	Added-value services and CI design
98100116	184 x 376 x 253	RCD 40 A 4-pole type A MCB 16 A 3-pole+N, C	Type 2 11 kW	LED	RCD A IP-41 ABS		
98500100	270 x 310 x 275	RCD 40 A 4-pole type A MCB 16 A 3-pole+N, C PE-monitoring	Type 2 11 kW	LED	RCD A IP-41		

The listed articles represent a current selection from the product line. In addition to this, there are many other variants of charging point – charging power – operation – technology and CI. Contact our specialists.

Pedelec cabinet with accessories



Charging possibility for e-Bikes / electric bicycles

Without doubt, the most interesting options are cabinets with lockable compartments in which the cyclist can charge his/her battery using a charger when the door is locked, and also provides space for secure storage of the helmet, gloves, glasses and backpack. A deposit key or ingenious electronics offer the necessary security – similarly to the situation in swimming pools or leisure parks.

The pedelec cabinet from Walther is available in an extremely wide range of variants. Depending on the number of compartments in the individual units (4 or 6 compartments), it is also possible to combine several cabinets with one another. Each cabinet includes a Schuko socket with a residual current device and circuit breaker. To provide a holistic energy concept, it is also possible to install solar panels and/or wind turbines on the pedelec cabinet.

Combining simple bicycle racks with socket strips represents a low-cost alternative. This allows a charging facility to be provided for electric bicycles in a straightforward manner.

6



Socket strip 651 00 01



821 41 001



M BEP0 1210 40



M CD90 2200 40



On request, pedelec cabinets from Walther can also be equipped with alternative energy sources such as small wind turbines or solar panels. In this case, the energy source is installed on the roof of the cabinet, and supplies the pedelec cabinet either directly or via an inverter. Projects of this kind have already been implemented successfully in customers' orders.

6

Art. no.	Enclosure W x H x D (mm)	Residual current devices and circuit breakers	Charging point and charging power	Identification and operation	Technology	Data communication	Added-value services and CI design
M CD90 1201 40	1500 x 2250 x 500	RCBO 16 A 2-pole type A	3 x Schuko	LED	6.9 kWh 6 x		RAL
M CD90 2200 40	1500 x 2250 x 500	RCBO 16 A 2-pole type A	3 x Schuko	LED	RCBO A 6 x		RAL
M CD90 2290 40	1500 x 2250 x 500	RCBO 16 A 2-pole type A	3 x Schuko	RFID LED	RCBO A 6 x		RAL
M BEP0 1210 40	1500 x 2250 x 500	RCBO 16 A 2-pole type A	2 x Schuko	LED	RCBO A 4 x		RAL



Marketing aspects of your charging infrastructure



Design foils: Formulate your own E-Mobility message

Individual, optical design of your charging station allows you to present not only logos and CI livery but also the highest quality subjects using design foils. This gives you the possibility of using your charging station as an active medium for your company's own E-Mobility message. Today, the majority of our customers are

already making active use of this possibility. Below, you can see excerpts from our internal selection process to define the design foils that are used.



Design foils:
Our Marketing department will be pleased to assist you in working out individual designs.



Make use of the double benefit!



Electric mobility attracts public attention. The focus on this topic in the media and amongst politicians means that people are being made more aware of electric mobility. Make use of this public interest to establish a double benefit on your charging stations.

For example, presentations (company profiles, upcoming events, etc.) can be shown on the screen, while an interactive menu system can provide product information (tariff systems, special offers, etc.) or even show a slideshow and short video films. All of this can support you in communicating your individual marketing message in the area of electric mobility. You can keep your content up to date at all times via a radio link, hard-wired transmission or SD card. Generate continuous footfall at your charging stations using innovative procedures such as mini-quizzes on the touchscreen, with the opportunity for customers to win prizes. As a result, the charging station is not just a charging point for electric cars, but also a real marketing instrument for your company.



Company or product presentation as a PowerPoint presentation or short image film.



Interactive display of products, offers or tariffs.



Operator's event calendar.

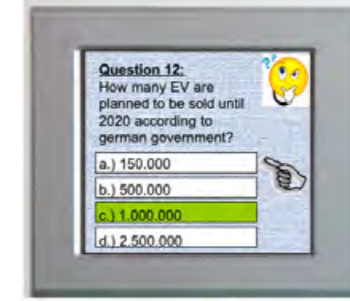

Sample E-Mobility quiz. Points scored can be redeemed when shopping.



Illuminated advertising in the top unit enables your customers to find the charging station even in the dark.

Product range of charging cables, charging connections and accessories

The IEC 62196 standard for charging connections and the IEC 61851 standard for charging infrastructure describe and define the individual components and configurations for charging electric vehicles. Walther offers all the products necessary for charging with alternating or three-phase current (AC charging). Charging powers from 3 kW to 44 kW can be provided in this case.

The energy flow is from the charging device (charging station or E-BoxX) through the corresponding charging cable to the electric vehicle. The charging device contains one or more charging points, each equipped with one charging socket. This provides the charging energy in the desired power range (16 A, 32 A or 63 A). The charging cable provides the electrical connection between the charging socket and the vehicle. When there are plug-in charging cables on the infrastructure side, the standard defines a charging plug (type 2) matching the charging socket and, on the vehicle side, a vehicle connector (type 1 or type 2) matching the vehicle inlet. The type of vehicle connector is selected according to the vehicle, as is the max. charging current and cable length.

The vehicle inlet is, it goes without saying, a component of the electric vehicle. Here, vehicles of the first generation use the so-called type 1 for single-phase charging whereas current vehicles use type 2 both for single-phase and for three-phase charging at higher power.

EV-Tester/Simulator

Following the installation of charging devices or in case of service, it is possible to check they are functioning correctly by simulating an electric vehicle. The devices are available as a variant for type 1, type 2 or as a combination device.

Charge controller CC 2

The charge controller controls a charging point and permits compact load control up to max. 70 A. The charge controller includes the cable detection (PP resistance coding), a PWM generator as well as activation of the charging contactor and the electromechanical interlock of the charging socket.



Your contact
in all questions relating to charging cables, charging connections and accessories

Nikola Milosavljevic
Tel.: +49 63 51 4 75-288
nikola.milosavljevic@walther-werke.de

Charging cables



Charging cables with full communication (mode 2 and 3), straight or spiral. Type 2 charging plug with type 1 or type 2 vehicle connector for single-phase and/or three-phase charging.

Expansion possibility

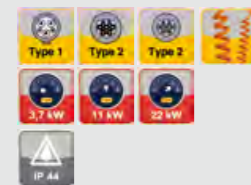

Charging sockets and vehicle inlets



Charging sockets (type 2) for the charging infrastructure (charging station or E-BoxX units) and vehicle inlets (vehicle side) for using plug-in charging cables up to 63 A.

Expansion possibility

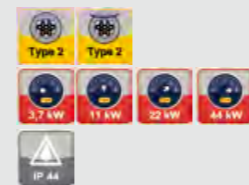

Charging plug and vehicle connector



Charging plug (type 2) for connection to the charging infrastructure (charging station or E-BoxX units) for use on plug-in charging cables up to 63 A. Vehicle connector type 1 and type 2 for the vehicle side.

Expansion possibility



Accessories



EV-Tester/Simulator for installation, function check and service on charging infrastructure. Charge controller for complete control of a charging point and communication with the electric vehicle.

Expansion possibility

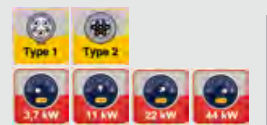

Overview of electric cars and necessary charging cables

The electric vehicles that will be coming onto the market over the next few months, or are already available, still have different charging connections today. The international standard that specifies type 1 and type 2 was only approved in the middle of 2012. As a result, this standardisation will only feature in manufacturers' vehicles in the medium-term. Nevertheless, Walther offers you the corresponding solutions for the most common models, so that you will be able to charge your electric car as well. The following display shows you possible ways in which you can achieve a particular charging method with Walther products. As you would expect, there are many other possibilities. In this way, you can basically decide whether you would like the

cable fixed to your E-BoxX or E-Station, or whether the vehicle will be connected to the charging point using the charging cable. Also, the charging cable can be configured as straight or spiral. For more information and configuration options, please refer to the corresponding sections in this catalogue, or contact one of our sales employees directly. We will be happy to help you find the solution that is optimum for you.

Type 1 charging possibilities



Manufacturer	Market launch
Chevrolet Volt	2010
Citroën C-Zero	2010
Ford Focus EV	2012
Mitsubishi i-MiEV	2010
Nissan Leaf	2011
Opel Ampera	2011
Peugeot iOn	2010
Renault Fluence Z.E.	2011
Renault Kangoo Maxi Z.E.	2011
Renault Kangoo Z.E.	2011
Smart Fortwo ED	2012

Type 2 charging possibilities



Manufacturer	Market launch
BMW Megacity	2013/2014
eRUF Roadster	2011
Karabag 500E	2012
Mercedes E-Cell	2013
Mercedes Vito	2010



Charging cables



Charging cables

The charging cable provides the electrical connection between the charging socket and the electric vehicle and, with plug-in charging cables, contains a charging plug (type 2) on the infrastructure side matching the charging socket and, on the vehicle side, a vehicle connector (type 1 or type 2) matching the vehicle inlet.

The IEC 62196 (charging connection) and IEC 61851 (charging infrastructure) standards permit charging currents of 13, 16/20, 32 or 63 A. The appropriate charging cables are available depending on the vehicle, weight, handling etc. The designations mode 2 and mode 3 describe the type of charging, while the designations type 1 and type 2 refer to the connected charging plug or vehicle connector. The type of vehicle connector is selected according to the vehicle, also the max. charging current and cable length.

Charging cables with full communication (mode 3)

These charging cables guarantee safety according to the standard via the charging station or E-BoxX, with RCD (residual current device) and cable protection. They are used in all vehicles of the new generation and make it possible to charge at 13 A to 32 A. The charging cable can have different cable cross sections depending on the charging current.

Depending on the requirement and application, the charging cables can have a straight or spiral configuration. Special solutions are our strength.

Charging cable with in-cable control box (IC-CPD) for mode 2

For charging in domestic applications (generally on an existing Schuko socket), it is necessary to have a charging cable with a so-called in-cable control box (IC-CPD). This must replace an RCD (residual current device) if the electrical installation is "unknown", as well as providing the necessary safety devices and communication with the vehicle. The international standardisation for this (IEC 62752-1 in conjunction with IEC 61851-3) has not been completed as at the end of 2012. Walther is working both on a version for a national connector type (single country) and on a multi-country version. Please contact us if you are interested in obtaining more information and would like to know the current status.



Mode 3, type 1 to type 2, straight cable



Mode 3, type 1 to type 2, spiral cable



Mode 3, type 2 to type 2, straight cable



Mode 3, type 2 to type 2, spiral cable



Mode 2, single-country

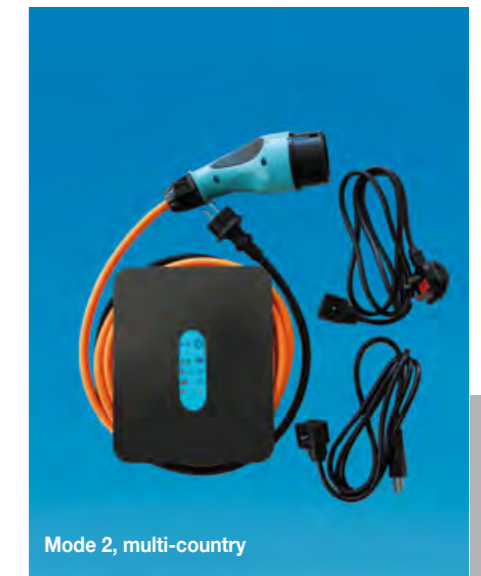

Mode 2, multi-country

Charging cables mode 3

Cable S05BQ-F as a straight version in orange

Art. no.	Rated current	Charging plug	Vehicle connector	Cable cross section	Cable length*
977 13 00 100	16 A 3-phase	Type 2, 7-pole	Type 2, 7-pole	5 x 2,5 + 0,5	5 m
977 13 00 101	16 A 1-phase	Type 2, 7-pole	Type 1, 5-pole	3 x 2,5 + 0,5	5 m
977 33 00 100	32 A 3-phase	Type 2, 7-pole	Type 2, 7-pole	5 x 6 + 0,5	5 m
977 33 00 101	32 A 1-phase	Type 2, 7-pole	Type 1, 5-pole	3 x 6 + 0,5	5 m

* Special lengths, special colours, with spiral or as connection cable on request.

Charging cables mode 2

Cable S05BQ-F as a straight version in orange

Art. no.	Rated current	Mains plug	Vehicle connector	Cable cross section	Cable length*
On request	16 A 1-phase	Schuko plug	Type 2, 7-pole	3 x 2,5 + 0,5	5 m
On request	16 A 1-phase	Schuko plug	Type 1, 5-pole	3 x 2,5 + 0,5	5 m
On request	16 A 1-phase	Multi-country	Type 2, 7-pole	3 x 2,5 + 0,5	5 m
On request	16 A 1-phase	Multi-country	Type 1, 5-pole	3 x 2,5 + 0,5	5 m

* Special lengths, special colours, with spiral or as connection cable on request.

Charging sockets and vehicle inlets



Charging socket with cover, without interlock



Charging socket with cover and interlock



Charging socket without cover, without interlock

Charging sockets

Charging sockets (type 2 acc. to IEC 62196-2) are components of the charging infrastructure (charging station or E-BoxX units) and make it possible to use plug-in charging cables. Charging sockets are equipped with female contacts and, according to the configuration, are defined for single-phase and three-phase charging of electric vehicles from 16 A to 63 A with the same contact arrangement. The stipulations of the standard require that charging sockets must have an interlocking mechanism that blocks the charging plug during the charging procedure to prevent it from being disconnected inadvertently.

Walther achieves this using an electromechanical interlock with an integrated microswitch for position feedback. In charging sockets without interlocking, this must be implemented by the user in order to comply with the standard.

Communication via both control contacts CP and PP with the electric vehicle means the charging socket is only locked once the charging cable has been connected at both ends. Also, the design of the system means that the energy is not switched on until this point, thus ensuring that there is never a danger of an electric shock or that the cable could be plugged in or disconnected under load. Charging sockets can be supplied with or without lids.

Vehicle inlets

The vehicle inlet for electric vehicles of the new generation (type 2 acc. to IEC 62196-2) is a component of the electric vehicle and makes it possible to use plug-in charging cables. Vehicle inlets are equipped with male contacts, and, according to the configuration, are defined for single-phase and three-phase charging of electric vehicles from 16 A to 63 A with the same contact arrangement.

The vehicle inlet is installed in the vehicle by the car maker. Depending on the installation location and situation, customer-specific adaptations can be implemented in the external holding and attachment area. The electrical connection is performed from the back, or else if required a prefabricated version is supplied. If required, an electromechanical interlock identical to that of the charging socket is available. Depending on the installation orientation intended, it is also possible for a drainage opening to be used. Seals can be used as an option, according to the standard. Optionally, a protective cap is available in order to achieve IP rating IP 44.



Vehicle inlet



Vehicle inlet with protective cap



Vehicle inlet with interlock

Charging sockets, straight

Screw terminal connection, IP 44 (in devices without lid, IP 44 only when connected)

Art. no.	Rated current	Lid	Electromagnetic interlock*	Conductor cross section		Weight (g)
				rigid	flexible	
741 00 00 00	16 A	no	yes	4 to 25 mm ²	2,5 to 16 mm ²	380
741 00 01 00	16 A	yes	yes			400
743 00 00 00	32 A	no	yes	4 to 25 mm ²	2,5 to 16 mm ²	380
743 00 01 00	32 A	yes	yes			400
746 00 00 00	63 A	no	yes	4 to 25 mm ²	2,5 to 16 mm ²	380
746 00 01 00	63 A	yes	yes			400

* All versions are also available without electromechanical interlock. Required connection cable 1 m, art. no. 790 00 00 01

Vehicle inlets, straight

Screw terminal connection, IP 44 (in devices without lid, IP 44 only when connected)

Art. no.	Rated current	Protective cap*	Electromagnetic interlock	Conductor cross section		Weight (g)
				rigid	flexible	
761 00 00 00	16 A	Art. no. 790 00 00 02	yes	4 to 25 mm ²	2,5 to 16 mm ²	430
761 00 02 00	16 A	as option	no			300
763 00 00 00	32 A	Art. no. 790 00 00 02	yes	4 to 25 mm ²	2,5 to 16 mm ²	430
763 00 02 00	32 A	as option	no			300
766 00 00 00	63 A	Art. no. 790 00 00 02	yes	4 to 25 mm ²	2,5 to 16 mm ²	430
766 00 02 00	63 A	as option	no			300

* Push-on protective cap art. no. 790 00 00 02



Charging plug type 2, crimp connection

Vehicle connector type 2, screw terminal connection

Charging plug type 2, screw terminal connection

Type 2 charging plugs

Art. no.	Rated current	Connection	Contact pattern arrangement	Terminal cross section	Cable ø in mm	Weight (g)
721 00 00 15	16 A	Screw terminal connection	Type 2, 7-pole	2,5 to 6 mm ²	7,5 to 18	345
9721 02 00 00	16 A	Crimp connection	Type 2, 7-pole	2,5 to 6 mm ²	7,5 to 18	345
723 00 00 15	32 A	Screw terminal connection	Type 2, 7-pole	2,5 to 6 mm ²	7,5 to 18	345
9723 02 00 00	32 A	Crimp connection	Type 2, 7-pole	2,5 to 6 mm ²	7,5 to 18	345

Charging plug

The charging plug (type 2 acc. to IEC 62196-2) is a component of a plug-in charging cable for operation on charging sockets of charging stations or E-BoxX units. Charging plugs are equipped with male contacts, and, according to the configuration, are defined for single-phase and three-phase charging of electric vehicles from 16 A to 63 A with the same contact arrangement. This means charging powers from 3 kW to 44 kW per hour can be achieved.

The charging plug and type 2 vehicle connector not only have the main current contacts (L1, L2, L3, N and PE) but also two additional control contacts (CP and PP) for data transfer as well as cable detection and coding. The CP (control pilot) control line establishes the connection between the charging device and the charger in the electric vehicle. Coding is installed in the charging plug for cable detection. This is evaluated by the charging device and taken into account when specifying the charging current. Charging plugs are available both with screw terminal or crimp connections, as well as with special colours as an option.

Vehicle connector

The vehicle connector (type 2 acc. to IEC 62196-2) is a component of a plug-in charging cable for operation on the vehicle inlet of the electric vehicle. Vehicle connectors are equipped with female contacts and, according to the configuration, are defined for single-phase and three-phase charging of electric vehicles from 16 A to 63 A with the same contact arrangement. This means charging powers from 3 kW to 44 kW per hour can be achieved.

Vehicle connectors also provide the charging interface to the electric vehicle in charging stations and E-BoxX units with a fixed cable. Coding is installed in the vehicle connector for cable detection. This is evaluated by the electric vehicle and taken into account in the charging current.

The IEC 62196-2 standard also defines a type 1 vehicle connector for single-phase charging up to 32 A (Europe) for first-generation electric vehicles from Japan, the USA etc. The type 1 vehicle connector not only has the main current contacts (L, N and PE) but also two additional control contacts (CP and CS) for data transfer and interlocking. Walther also offers the corresponding solution.



Vehicle connector type 1, crimp connection

Vehicle connectors type 1 and type 2

Art. no.	Rated current	Connection	Contact arrangement	Terminal cross section	Cable ø in mm	Weight (g)
731 00 00 15	16 A	Screw terminal connection	Type 2, 7-pole	2,5 to 6 mm ²	7,5 to 18	360
733 00 00 15	32 A	Screw terminal connection	Type 2, 7-pole	2,5 to 6 mm ²	7,5 to 18	360
731 12 14 00	16 A	Crimp connection	Type 1, 5-pole	2,5 to 6 mm ²	11	400
733 12 14 00	32 A	Crimp connection	Type 1, 5-pole	2,5 to 6 mm ²	17,5	400
731 12 06 00	16 A	Crimp connection	Type 1, 5-pole	2,5 to 6 mm ²	11	380
733 12 06 00	32 A	Crimp connection	Type 1, 5-pole	2,5 to 6 mm ²	17,5	380

EV-Tester/Simulator, charge controller



EV-Tester/Simulator

Once charging devices have been installed, and when servicing is required, it is possible to check they are functioning correctly by simulating an electric vehicle. This is particularly important if no suitable electric vehicle is available. Using built-in toggle switches, all devices can simulate the coding resistance in the charging plug of the charging cable (13 A, 16/20 A, 32 A or 63 A). The same applies to the specification of vehicle status B, C and D, and thus to switching the charging energy on and off. The test of the PE connection to the vehicle as well as a BNC output for CP measurement are also present in all devices. LEDs indicate the switching status of the charging contactor in the charging station or E-BoxX. Additional functions are included, depending on the configuration (hand-held device or service case): Test sockets or Schuko socket for load switching and FI measuring device, resistance measurement PP – PE for the cable coding and CP – PE for the interlocking as well as a residual current for FI tripping that can be generated by buttons.

EV-Tester/Simulator for type 2 charging socket as hand-held device: LED indicators for L1, L2 and L3. Test sockets optional.

EV-Tester/Simulator for type 2 charging socket as service case: LED indicators for L1, L2 and L3. Schuko socket for load switching (L1), Measurement of resistance PP – PE by built-in instrument, switchable residual current for RCD tripping.

EV-Tester/Simulator for type 1 charging socket as service case: LED display for L1. Measurement of resistance CS – PE (latch) by built-in instrument, switchable residual current for RCD tripping. Schuko socket for load switching (L1) optional.

EV-Tester/Simulator for type 1 and type 2 charging socket as service case: LED indicators for L1, L2 and L3. Measurement of resistance PP – PE and CS – PE (latch) via built-in instrument, switchable residual current for RCD tripping. Schuko socket for load switching (L1).



EV-Tester/Simulator and charge controller

Art. no.	Device	Connection infrastructure	Enclosure version	Load switching
780 00 15 01	EV-Tester/Simulator	Type 2, 7-pole	Hand-held device	no
780 00 15 02	EV-Tester/Simulator	Type 2, 7-pole	Hand-held device	Test sockets 4 mm
780 00 15 03	EV-Tester/Simulator	Type 2, 7-pole	Service case	Schuko socket
780 12 00 01	EV-Tester/Simulator	Type 1, 5-pole	Service case	no
780 12 10 24	EV-Tester/Simulator	Type 1, 5-pole and type 2, 7-pole	Service case	Schuko socket
780 00 00 01	Charge controller CC 2	Screw terminals	Device for DIN-rail mounting, 4 modules	Screw terminals

Charge controller CC 2

The charge controller controls a charging point and permits compact load control up to max. 70 A. The design as a device for DIN-rail mounting permits installation on a DIN rail with a width of 4 modules.

The charge controller includes the cable detection (PP resistance coding), a PWM generator as well as activation of the charging contactor and the electromechanical interlock of the charging socket. With Walther, emergency unlatching on power failure is guaranteed, without external auxiliary energy. The PWM control can be adapted to the mains power using corresponding digital inputs (BCD) for applications and specifications via smart grid or decentralised control for energy distribution.

Basic knowledge in the area of electric mobility

A great deal has already been written about the fundamentals of electric mobility. Here, we present a short, sharp introduction to the main technical features.



Standardisation

Standards are essential prerequisites of properly functioning and future-oriented electric mobility, in order to ensure compatibility amongst systems and rapid dissemination across borders. The IEC 62196-1 and IEC 62196-2 standards describe charging plugs, charging sockets, vehicle connectors and vehicle inlets for charging on AC or DC voltage, while the IEC 62196-3 standard deals with combined plugs and sockets for AC and DC voltage. The IEC 61851-1 standard describes the electrical equipment of conductive (hard-wired) charging systems with connection configurations, basic communication, charging mode and safety devices. HD 60364-7-722 defines the installation provisions for low-voltage switchgear. Requirements on the enclosures can be found in IEC 61493-7, while requirements on the electric vehicle are given in ISO 17409. Walther has been involved in all these standardization committees right from day one.

Charging connections

The IEC 62196-2 standard describes the three different plug-and-socket systems: Type 1 (developed in Japan) for single-phase charging up to 32 A, type 2 (developed with input from Walther on the standardisation committee) for single-phase to three-phase charging up to 63 A and type 3 (developed in Italy) with different geometries up to 63 A. Walther offers products and charging options for all current electric vehicles equipped with type 1 and type 2 as charging connection.



Vehicle connector
Type 1



Charging plug
Type 2



Charging plug
Type 3

Charging connector	AC	230 V 1-phase	400 V 3-phase
Type 1	16 A 32 A	3,7 kW 7,4 kW	- -
Type 2	13 A 16 A 32 A 63 A	3,0 kW 3,7 kW 7,4 kW -	9,0 kW 11,0 kW 22,0 kW 43,5 kW
Type 3	up to 63 A	up to 3,7 kW	up to 43,5 kW

Charging types

Safety is top priority when it comes to charging types and charging modes. Of course, this applies to AC charging and DC charging. For AC charging on alternating current (single-phase and three-phase), Walther offers what is probably the widest range of products for the charging infrastructure – from medium voltage through to the vehicle equipment connector – all included in this catalogue. Products for DC are in the pipeline.

When it comes to the connection types, the dominant options are case B as a double-ended plug-in charging cable and case C as a charging cable fixed to the charging station or E-BoxX.

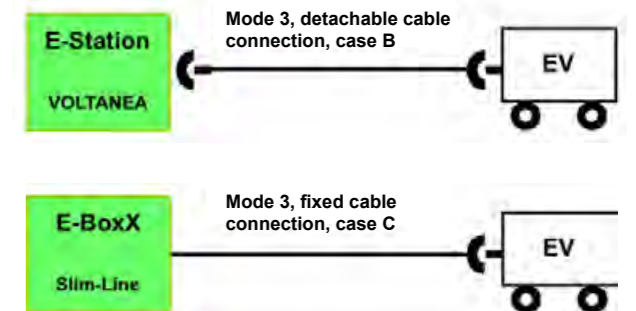

Charging modes

Charging acc. to mode 2 describes charging from the domestic or CEE socket, which means the existing installation is used. In mode 3, charging takes place on a new charging infrastructure that is to be set up, with communication to the electric vehicle. This concerns the charging station (E-Station), wallbox (E-BoxX) as well as the associated charging cable.

Walther does not offer products for charging acc. to mode 1, because it is not possible to assume that older installations will have RCDs (residual current devices).

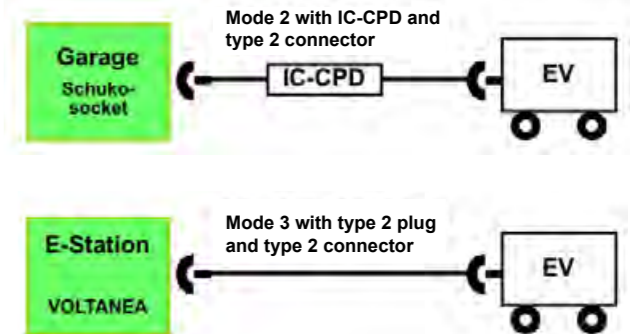

Basic communication

The IEC 61851-1 standard describes basic communication for mode 2 and mode 3 between the charging device and electric vehicle. The max. available charging current is specified for the electric vehicle via the CP control contact using a PWM signal (PWM = pulse width modulation). The vehicle uses the same signal to control the activation and deactivation of the charging voltage according to the battery status. At Walther, the PWM signal from the charge controller is generated with the corresponding monitoring functions.

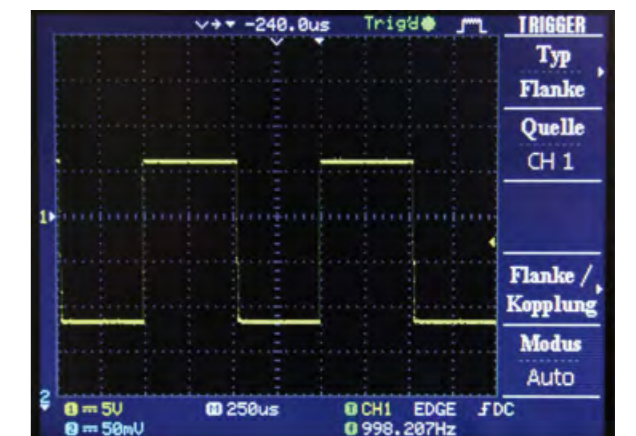

PWM signal 32 A

Training courses

Electric mobility is an exceedingly dynamic topic. Standardisation efforts at national and international level bring new insights and developments with them almost on a weekly basis. Any player wishing to present itself as a competent contender needs to have an extensive and up-to-date store of knowledge.

To ensure that the training courses address the individual information requirement as far as possible, we offer various training modules at Walther so that you can devote your valuable time to the “right” seminar.

Would you basically like to find out about the current status of electric mobility because your company has identified market opportunities in this new sphere of business? Or are you in the electrical wholesale trade and would you like your employees to be trained to handle consulting and sales? In order to respond to all the questions posed by specific customers and standards, it is important to build up a deep knowledge if you are going to be successful in this highly technical application area. The last training module is aimed at electricians. In addition to providing an introduction to the basics of the topic, this course focuses on communicating the technical product capabilities that are necessary for installation, maintenance and troubleshooting. It goes without saying that you should also experience electric mobility. A drive in our electric car should “electrify” you for this new market.

The training courses are all held in our headquarters at Eisenberg (Rhineland Palatinate). The fee for attending a seminar is € 250 per person which includes beverages, a midday snack and seminar documents. The dates of the training courses are set every quarter based on demand.

Please contact +49 6351 4750 to enquire about the current schedule.



Expertise through knowledge

General principles of electric mobility

1



Contents:

- Principles and standardisation
- Charging connections
- Charging cables
- Charging stations
- Home charging stations
- EV-Tester/Simulator
- Communication and interface
- Electric vehicle
- Installations with scope for future expansion

Important information for consulting and sale in the electrical wholesale trade

2



Contents:

- Principles of electric mobility
- Market observation and opportunities for the electrical trade
- Charging infrastructure for sales channel of the electrical wholesale trade
- Product selection and properties
- Guidelines for the consultation conversation acc. to user groups
- Marketing support and marketing tools

Installation, maintenance and troubleshooting

3



Contents:

- Charging stations
- Home charging stations
- Installation prerequisites
- Parameter setting and start-up
- Charging infrastructure
- Tools for testing, simulation and fault diagnosis
- Communication and data exchange with external systems

Your contacts at Walther

Sales of E-Mobility - internal sales



Nikola Milosavljevic
Tel.: +49 63 51 4 75-288
Fax: +49 63 51 4 75-227
nikola.milosavljevic@walther-werke.de



Jens Metzger
Tel.: +49 63 51 4 75-239
Fax.: +49 63 51 4 75-227
jens.metzger@walther-werke.de

Project management system solutions charging infrastructure (E-Station / E-BoxX)



Günther Wilhelm
Tel.: +49 35 83 77 24-145
Mobile: +49 173 66 83 50 66
guenther.wilhelmi@walther-werke.de



Knut Dwornikiewicz
Tel. +49 35 83 77 24-144
knut.dwornikiewicz@walther-werke.de

Project management OEM



Carsten Getta
Tel.: +49 63 51 4 75-281
Fax.: +49 63 51 4 75-5281
carsten.getta@walther-werke.de

Marketing, model devices for events



Martina Wunderlich-Beck
Tel.: +49 63 51 4 75-219
Fax: +49 63 51 4 75-5219
martina.wunderlich-beck@walther-werke.de

International Offices

Austria

Walther Electric GmbH
Bayernstraße 39
A-5071 Wals-Siezenheim
Tel.: +43 6 62 85 47 00-0
Fax: +43 6 62 85 46 32
mail@schurrer.at
www.walther-werke.de

France

F. Walther Sarl
100, rue Edouard Branly
F-59500 Douai
Tel.: +33 327 081 717
Fax: +33 327 976 833
contact@walther-fr.com
www.walther-fr.com

Great Britain

F. Walther Electrics Ltd.
Unit 4, Cromwell Trading Estate
Cromwell Road
GB-Bredbury, Stockport
Cheshire SK6 2RF
Tel.: +44 1 61 4 94 12 33
Fax: +44 1 61 4 94 50 55
mail@walther.demon.co.uk

USA

F. Walther Electric Corp.
12 World's Fair Drive Unit F
USA-Somerset, NJ 08873
Tel.: +1 7 32 537-9201
Fax: +1 7 32 537-9209
info@waltherelectric.com
www.waltherelectric.com

Walther E-Mobility icons: Equipment features at a glance

Charging point

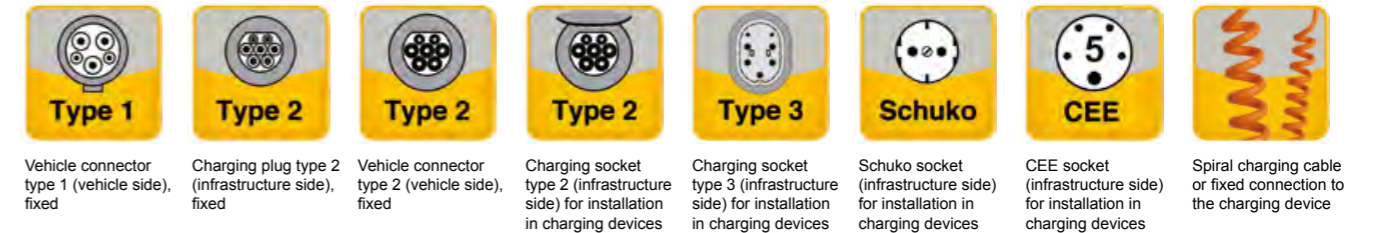

Type 1: Vehicle connector type 1 (vehicle side), fixed
Type 2: Charging plug type 2 (infrastructure side), fixed
Type 2: Vehicle connector type 2 (vehicle side), fixed
Type 2: Charging socket type 2 (infrastructure side) for installation in charging devices
Type 3: Charging socket type 3 (infrastructure side) for installation in charging devices
Schuko: Schuko socket (infrastructure side) for installation in charging devices
CEE: CEE socket (infrastructure side) for installation in charging devices
Spiral charging cable: Spiral charging cable or fixed connection to the charging device

Charging power



3,7 kW: Charging device or charging cable for max. 3.7 kW (16 A)
7 kW: Charging device or charging cable for max. 7 kW (32 A)
11 kW: Charging device or charging cable for max. 11 kW (16 A)
22 kW: Charging device or charging cable for max. 22 kW (32 A)
44 kW: Charging device or charging cable for max. 44 kW (63 A)
OCPP: Communication with the charging device via mobile phone
TCP/IP: Communication with the charging device via OCPP protocol
TCP/IP: Communication with the charging device via TCP/IP

Identification and operation

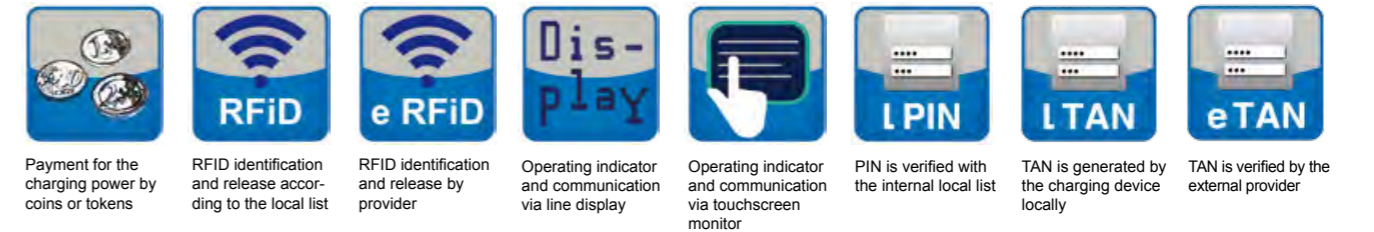

Payment: Payment for the charging power by coins or tokens
RFID: RFID identification and release according to the local list
eRFID: RFID identification and release by provider
Display: Operating indicator and communication via line display
PIN: Operating indicator and communication via touchscreen monitor
PIN: PIN is verified with the internal local list
LTAN: TAN is generated by the charging device locally
eTAN: TAN is verified by the external provider

Technology



DJB: Identification and release using key-operated switch
RCD A: Identification and release using knob switch
LED: Signalling and operating indicator via light-emitting diodes (LEDs)
DJB: Domestic junction box (DJB) at the supply point
RCD A: RCD (residual current device) type A
RCD B: RCD (residual current device) type B
external RCD: RCD (residual current device) in upstream installation



IP 44: IP rating IP 44
ABS: Enclosure of the charging device made from plastic
Stainless Steel: Enclosure of the charging device made from stainless steel
Alu: Enclosure of the charging device made from aluminium
int.meter: Internal energy meter (single-phase or three-phase) for consumption measurement and reading
meter: Visible energy meter (single-phase or three-phase) for consumption measurement and reading
data: Energy meter (single-phase or three-phase) for consumption measurement and data recording



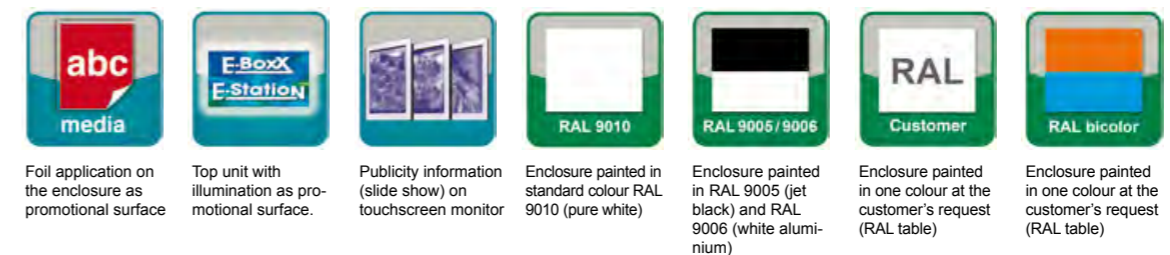



Added-value services and CI livery



abc media: Foil application on the enclosure as promotional surface
E-BoxX E-Station: Top unit with illumination as promotional surface.
RAL 9010: Publicity information (slide show) on touchscreen monitor
RAL 9010: Enclosure painted in standard colour RAL 9010 (pure white)
RAL 9005/9006: Enclosure painted in RAL 9005 (jet black) and RAL 9006 (white aluminium)
Customer: Enclosure painted in one colour at the customer's request (RAL table)
RAL bicolor: Enclosure painted in one colour at the customer's request (RAL table)

Walther E-Mobility icons: Equipment features at a glance

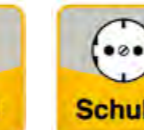
Charging point









							
Type 1	Type 2	Type 2	Type 2	Type 3	Schuko	CEE	
Vehicle connector type 1 (vehicle side), fixed	Charging plug type 2 (infrastructure side), fixed	Vehicle connector type 2 (vehicle side), fixed	Charging socket type 2 (infrastructure side) for installation in charging devices	Charging socket type 3 (infrastructure side) for installation in charging devices	Schuko socket (infrastructure side) for installation in charging devices	CEE socket (infrastructure side) for installation in charging devices	Spiral charging cable or fixed connection to the charging device

Charging power

						
3,7 kW	7 kW	11 kW	22 kW	44 kW	OCPP	TCP/IP
Charging device or charging cable for max. 3.7 kW (16 A)	Charging device or charging cable for max. 7 kW (32 A)	Charging device or charging cable for max. 11 kW (16 A)	Charging device or charging cable for max. 22 kW (32 A)	Charging device or charging cable for max. 44 kW (63 A)	Communication with the charging device via OCPP protocol	Communication with the charging device via TCP/IP

Data communication

Identification and operation







							
	RFiD	eRFiD	Dis- play		L PIN	L TAN	eTAN
Payment for the charging power by coins or tokens	RFiD identification and release according to the local list	RFiD identification and release by provider	Operating indicator and communication via line display	Operating indicator and communication via touchscreen monitor	PIN is verified with the internal local list	TAN is generated by the charging device locally	TAN is verified by the external provider

Technology

						
		LED	DJB	RCD A	RCD B	external RCD
Identification and release using key-operated switch	Identification and release using knob switch	Signalling and operating indicator via light-emitting diodes (LEDs)	Domestic junction box (DJB) at the supply point	RCD (residual current device) type A	RCD (residual current device) type B	RCD (residual current device) in upstream installation

						
IP 44	ABS	Stain- less Steel	Alu	6.9 kWh int. meter	6.9 kWh meter	6.9 kWh → data
IP rating IP 44	Enclosure of the charging device made from plastic	Enclosure of the charging device made from stainless steel	Enclosure of the charging device made from aluminium	Internal energy meter (single-phase or three-phase) for consumption measurement and reading	Visible energy meter (single-phase or three-phase) for consumption measurement and reading	Energy meter (single-phase or three-phase) for consumption measurement and data recording

Added-value services and CI livery

						
abc media	E-BoxX E-Station		RAL 9010	RAL 9005/9006	RAL Customer	RAL bicolor
Foil application on the enclosure as promotional surface	Top unit with illumination as promotional surface.	Publicity information (slide show) on touchscreen monitor	Enclosure painted in standard colour RAL 9010 (pure white)	Enclosure painted in RAL 9005 (jet black) and RAL 9006 (white aluminium)	Enclosure painted in one colour at the customer's request (RAL table)	Enclosure painted in one colour at the customer's request (RAL table)



Walther-Werke
 Ferdinand Walther GmbH
 Ramsener Straße 6
 67304 Eisenberg/Pfalz
 Telefon + (49) 63 51 / 475-0
 Fax + (49) 63 51 / 475-227
www.walther-werke.de
mail@walther-werke.de